

Errata

Title & Document Type: 3400B RMS Voltmeter User and Service Guide

Manual Part Number: 03400-90014

Revision Date: October 1992

About this Manual

We've added this manual to the Agilent website in an effort to help you support your product. This manual provides the best information we could find. It may be incomplete or contain dated information, and the scan quality may not be ideal. If we find a better copy in the future, we will add it to the Agilent website.

HP References in this Manual

This manual may contain references to HP or Hewlett-Packard. Please note that Hewlett-Packard's former test and measurement, life sciences, and chemical analysis businesses are now part of Agilent Technologies. The HP XXXX referred to in this document is now the Agilent XXXX. For example, model number HP8648A is now model number Agilent 8648A. We have made no changes to this manual copy.

Support for Your Product

Agilent no longer sells or supports this product. You will find any other available product information on the Agilent Test & Measurement website:

www.agilent.com

Search for the model number of this product, and the resulting product page will guide you to any available information. Our service centers may be able to perform calibration if no repair parts are needed, but no other support from Agilent is available.



Agilent Technologies

OTS LIBRARY

OTS LIBRARY



2400001027

User and
Service Guide

OTS LIBRARY

HP 3400B
RMS Voltmeter

© Copyright 1992
Hewlett-Packard Co.
All Rights Reserved.

Printing History
Edition 1, October 1992

New editions are complete revisions of the manual. Update packages, which are issued between editions, may contain additional information and replacement pages which you merge into the manual. The dates on this page change only when a new edition is published.

Certification

Hewlett-Packard certifies that this product met its published specifications at the time of shipment. Hewlett-Packard further certifies that its calibration measurements are traceable to the United States National Institute of Standards and Technology (formerly National Bureau of Standards), to the extent allowed by that organization's calibration facility, and to the calibration facilities of other International Standards Organization members.

Warranty

This Hewlett-Packard product is warranted against defects in materials and workmanship for a period of one year from date of shipment. Duration and conditions of warranty for this product may be superceded when the product is integrated into (becomes a part of) other Hewlett-Packard products. During the warranty period, Hewlett-Packard will, at its option, either repair or replace products which prove to be defective.

Warranty Service

For warranty service or repair, this product must be returned to a service facility designated by Hewlett-Packard.

For products returned to Hewlett-Packard for warranty service, the Buyer shall prepay shipping charges to HP and HP shall pay shipping charges to return the product to the Buyer. However, the Buyer shall pay all shipping charges, duties, and taxes for products returned to Hewlett-Packard from another country.

Limitation of Warranty

The foregoing warranty shall not apply to defects resulting from improper or inadequate maintenance by the Buyer, Buyer-supplied products or interfacing, unauthorized modification or misuse, operation outside of the environmental specifications for the product, or improper site preparation or maintenance.

The design and implementation of any circuit on this product is the sole responsibility of the Buyer. HP does not warrant the Buyer's circuitry or malfunctions of HP products that result from the Buyer's circuitry. In addition, HP does not warrant any damage that occurs as a result of the Buyer's circuit or any defects that result from Buyer-supplied products. **No other warranty is expressed or implied. Hewlett-Packard specifically disclaims the implied warranties of merchantability and fitness for a particular purpose.**

Exclusive Remedies

The remedies provided herein are the Buyer's sole and exclusive remedies. Hewlett-Packard shall not be liable for any direct, in-direct, special, incidental, or consequential damages, whether based on contract, tort, or any other legal theory.

Notice

The information contained in this document is subject to change without notice. **Hewlett-Packard makes no warranty of any kind with regard to this material, including, but not limited to, the implied warranties of merchantability and fitness for a particular purpose.**

Hewlett-Packard shall not be liable for errors contained herein or for incidental or consequential damages in connection with the furnishing, performance, or use of this material. No part of this document may be photocopied, reproduced, or translated to another language without the prior written consent of HP.

Restricted Rights

Use, duplication, or disclosure by the Government is subject to restrictions as set forth in subdivision (b)(3)(ii) of the Rights in Technical Data and Computer Software clause at 52.227-7013. Hewlett-Packard Co.
3000 Hanover Street
Palo Alto, California 94304

Safety

Do not install substitute parts or perform any unauthorized modification to the product. Return the product to an HP Sales and Service Office for service and repair to ensure that safety features are maintained.

Safety Symbols

Warning

Calls attention to a procedure, practice, or condition, that could possibly cause bodily injury or death.

Caution

Calls attention to a procedure, practice, or condition that could possibly cause damage to equipment or permanent loss of data.



Instruction manual symbol. Refer to the manual for specific Warning or Caution information to avoid personal injury or damage to the product.



Indicates hazardous voltages may be present.



Earth ground symbol.



Chassis ground symbol.

The HP 3400B is a true root-means-square (RMS) analog voltmeter capable of measuring ac voltages from 100 microvolts to 300 volts. It is extremely flexible for audio and RF measurements from 10 Hz to 20 MHz and allows you to measure broadband noise and fast rise-time pulses.

- Full-scale measurements of non-sinusoidal waveforms with crest factors (the ratio of peak voltage to RMS voltage) up to 10:1 can be made. At 1/10th of full scale, pulse trains with 0.01% duty cycle (100:1 crest factor) can be measured accurately.
- A single front-panel control selects one of 12 voltage ranges (1 mV to 300 V) or decibel ranges (-72 dBm to +52 dBm).
- A dc output is provided on the rear panel which is proportional to the front-panel meter reading. By using this voltage to drive auxiliary equipment, you can use the voltmeter as an RMS ac-to-dc converter.
- Suitable for bench use or can be rack-mounted using the available combining case or adapter frame accessories.

The HP 3400B is a form, fit, and function replacement for the original *HP 3400A*. Completely redesigned, the "B" version extends the bandwidth from 10 MHz, available with the "A" version, to 20 MHz. The *HP 3400B User and Service Guide* contains new specifications and calibration procedures for the improved performance of the HP 3400B. Updated schematics and replaceable parts lists are also included.

HP 3400B RMS Voltmeter

The Front Panel at a Glance

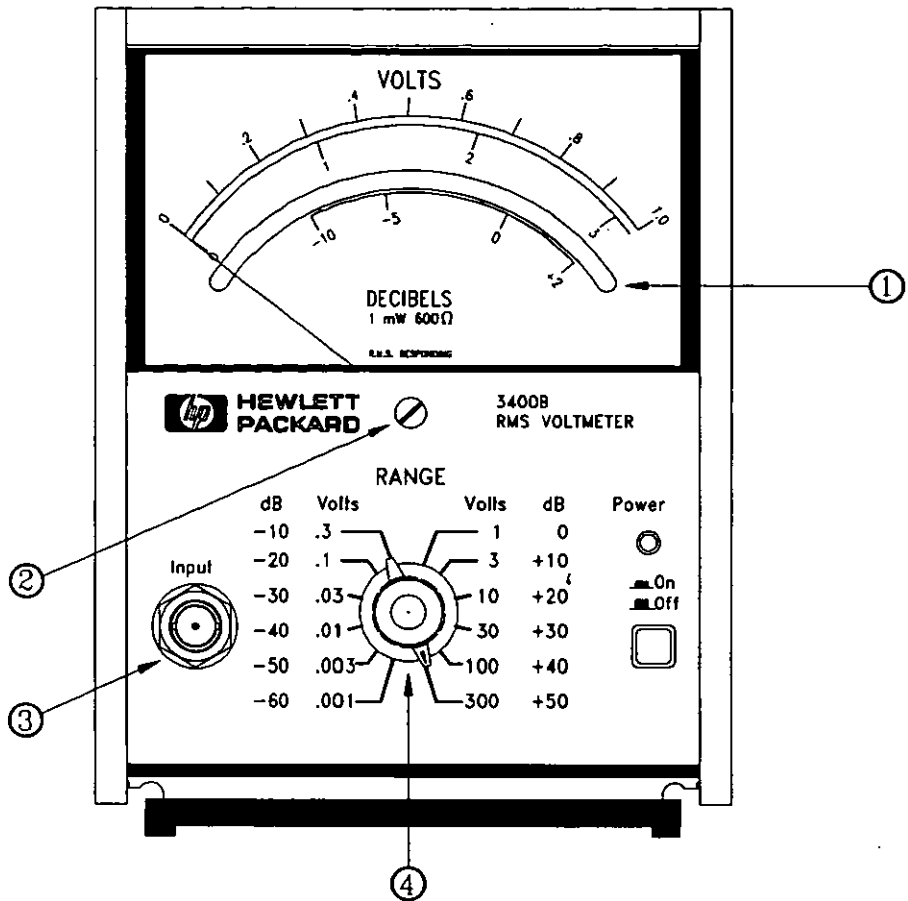

- 1 Direct reading meter (RMS volts and dB)
 2 Zero adjustment screw

- 3 Input BNC connector
 4 Range selector switch (volts and dB)

The Rear Panel at a Glance

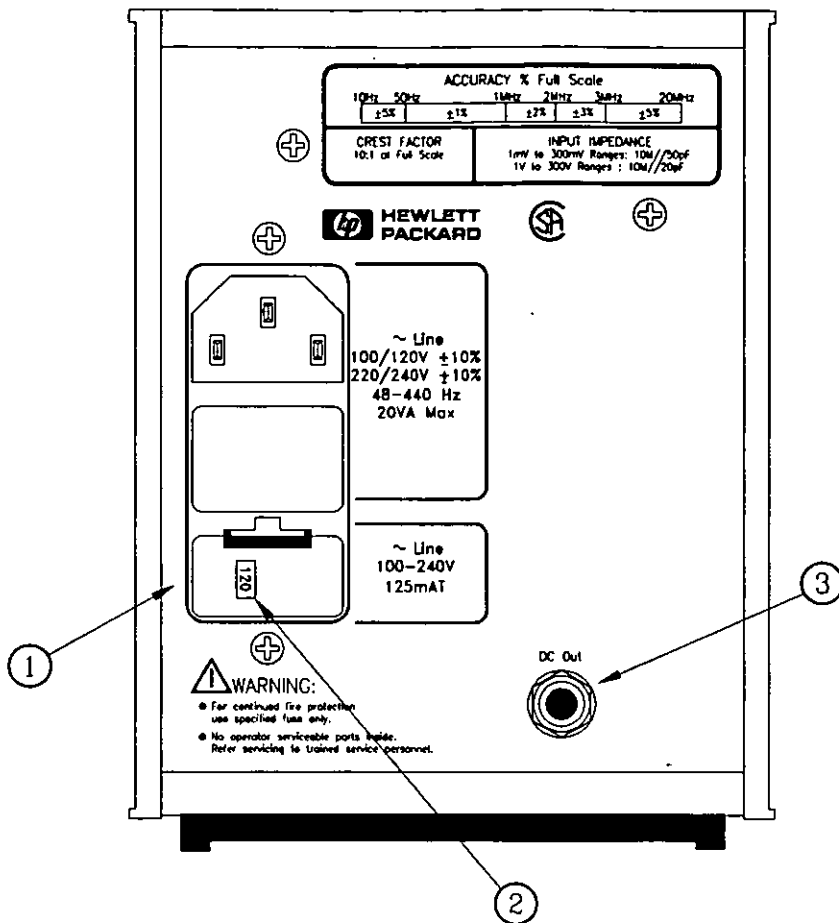

- 1 Power-line fuse-holder assembly
2 Power-line voltage setting

- 3 DC output jack. Provides -1 Vdc output at full-scale deflection; output is proportional to deflection; source impedance is 1 kΩ.

Specifications

Voltage Ranges: 1 mV, 3 mV, 10 mV, 30 mV, 100 mV, 300 mV, 1 V, 3 V, 10 V, 30 V, 100 V, 300 V full scale.

dB Range: -72 dBm to +52 dBm
(0 dBm = 1 mW into 600Ω).

Frequency Range: 10 Hz to 20 MHz

Response: Responds to RMS value (heating value) of input.

Measurement Accuracy: From 1/10th scale to full scale is % of full scale.
Temperature coefficient: $\pm 0.10\%$ per °C from 0°C to 20°C and 30°C to 55°C.
20°C to 30°C (1 Year)

Frequency	\pm % of Full Scale
10 Hz to 50 Hz	$\pm 5\%$
50 Hz to 1 MHz	$\pm 1\%$
1 MHz to 2 MHz	$\pm 2\%$
2 MHz to 3 MHz	$\pm 3\%$
3 MHz to 20 MHz	$\pm 5\%$

Note: The voltmeter may show a zero offset with no voltage applied to the input terminal.

AC-to-DC Converter Accuracy: Temperature coefficient: $\pm 0.10\%$ per °C from 0°C to 20°C and 30°C to 55°C.
20°C to 30°C

Frequency	\pm % of Full Scale
10 Hz to 50 Hz	$\pm 5\%$
50 Hz to 1 MHz	$\pm 0.75\%$
1 MHz to 2 MHz	$\pm 2\%$
2 MHz to 3 MHz	$\pm 3\%$
3 MHz to 20 MHz	$\pm 5\%$

Note: The voltmeter may show a zero offset with no voltage applied to the input terminal.

Input Impedance: 1 mV to 300 mV ranges: 10 MΩ shunted by < 50 pF. AC-coupled input.
1 V to 300 V ranges: 10 MΩ shunted by < 20 pF. AC-coupled input.

Crest Factor: (Ratio of peak-to-RMS amplitude of input.) 10:1 at full scale except where limited by maximum input, and inversely proportional to meter deflection (e.g. 20:1 at half-scale, 100:1 at tenth-scale).

AC Overload: 30 dB above full scale or 800 Vpeak, whichever is less, on each range.

Max. Continuous Input Voltage: 500 Vac peak at 1 kHz or 600 Vdc on all ranges.

Max. DC Input: 600 V on any range.

Response Time: For a step function, < 5 seconds to respond to final value.

DC Output: Negative 1 Vdc into open circuit for full scale deflection, proportional to meter deflection. 1 mA max; nominal source impedance 1 kΩ.

Output Noise: < 1 mV RMS

Power: 100 V / 120 V / 220 V / 240 V $\pm 10\%$.
48 Hz to 440 Hz, 10 Watts.

Weight: 2.2 kg (4.8 lbs); shipping: 4.0 kg (8.7 lbs).

Size: 18.5 cm (H) x 13.0 cm (W) x 29.7 cm (D)

Storage Temperature: -10°C to +60°C

Warnings and Cautions

Warning *No user serviceable parts inside. Refer servicing to trained service personnel.*

Avertissement *Ne contient pas d'élément que l'utilisateur puisse réparer. Confier la maintenance à un technicien qualifié.*

Warning *For continued fire protection, use specified fuse only.*

Avertissement *Pour maintenir la capacité de protection contre l'incendie, utilisez le fusible recommandé seulement.*

Warning *For protection from electrical shock hazard, power cord ground must not be defeated.*

Avertissement *Pour ne pas compromettre la protection contre le choc électrique, ne pas couper le circuit de continuité de masses de la fiche.*

In This Book

Quick Start Chapter 1 prepares the voltmeter for use and helps you get familiar with its front-panel features.

Calibration Procedures Chapter 2 provides a detailed description of the voltmeter's verification and adjustment procedures.

Theory of Operation Chapter 3 describes each functional block in the voltmeter.

Service Chapter 4 provides guidelines for returning your voltmeter to Hewlett-Packard for servicing.

Replaceable Parts Chapter 5 contains a detailed parts list for the voltmeter.

Backdating Chapter 6 describes the procedures involved with back issues of this manual.

Schematics Chapter 7 provides the voltmeter's schematics.

Contents

Chapter 1 Quick Start

- To prepare the voltmeter for use 11
- To select the range 13
- To use the DC output signal 14
- To rack mount the voltmeter 15

Chapter 2 Calibration Procedures

- Calibration Interval 19
- Time Required for Calibration 19
- Recommended Test Equipment 20
- Test Considerations 20
- Operation Verification Procedures 21
- Performance Verification Procedures 22
- Adjustment Procedures 28
- Test Connector Pinout 36

Chapter 3 Theory of Operation

- Block Diagram 39
- Input Attenuator 41
- Impedance Converter 41
- Post Attenuator 42
- Wideband Amplifier 42
- Chopper Op Amp / Thermocouple Pair 43
- Power Supplies 44
- Switch Board 45

Chapter 4 Service

- Operating Checklist 49
- To Replace the Power-Line Fuse 49
- Repackaging for Shipment 50
- Electrostatic Discharge (ESD) Precautions 50

Chapter 5 Replaceable Parts

To Order Replaceable Parts 52
Backdating and Parts Changes 52
Replaceable Parts: 03400-66522 (Main Assembly) 53
Replaceable Parts: 03400-66523 (Switch Assembly) 58
Manufacturer's Codes: 03400-66522 and 03400-66523 59
Replaceable Parts: HP 3400B Mainframe 60
Manufacturer's Codes: HP 3400B Mainframe 62

Chapter 6 Backdating 63

Chapter 7 Schematics

Mechanical Disassembly 67
Component Locator Diagrams 68
Input Attenuator, Impedance Converter, and Power Supplies 69
Relay Drivers and Post Attenuator 70
Wideband Amplifier, Chopper Op Amp, and Overload Detector 71
Switch Board Schematic 72

Index 73

Quick Start

Quick Start

One of the first things you will want to do with your voltmeter is to become acquainted with its front panel. We have written the exercises in this chapter to prepare the voltmeter for use and help you get familiar with some of its front-panel operations.

To prepare the voltmeter for use

The following steps help you verify that the voltmeter is ready for use.

1 Check the list of supplied items.

Verify that you have received the following items with your voltmeter. If anything is missing, contact your nearest Hewlett-Packard Sales Office.

- One double binding post to BNC adapter.
- One power cord.
- One 125 mA power-line fuse is installed.
- This *User and Service Guide*.

2 Verify the power-line voltage setting.

Four line voltage settings are available: *100, 120, 220, or 240 Vac*. The line voltage was preset at the factory to the proper value for your location. Change the voltage setting if it is not correct (see page 12).

A 125 mA fuse is installed when the voltmeter is shipped from the factory. This is the correct power-line fuse for 100, 120, 220, or 240 Vac operation.

3 Connect the power cord and turn on the voltmeter.

The front-panel **Power** indicator will light up when you turn on the voltmeter. Allow *five minutes* for the voltmeter to warm up and stabilize before making measurements.

Caution

Do not measure signals greater than 80 volts with 10 to 1 crest factor, otherwise, the maximum input rating of 800 volts peak will be exceeded. When measuring signals up to 80 volts with a 10 to 1 crest factor, use the double binding post to BNC adapter (or equivalent) supplied with the voltmeter.

Chapter 1 Quick Start
To prepare the voltmeter for use

- 1 Remove the fuse-holder assembly from the rear panel.**

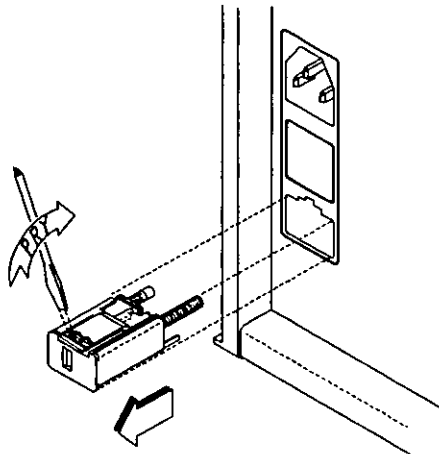

- 2 Remove the line-voltage selector from the assembly.**

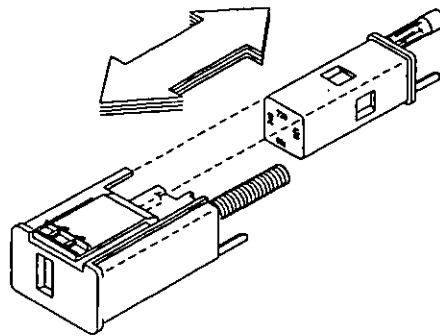

- 3 Rotate the line-voltage selector until the correct voltage appears in the window.**

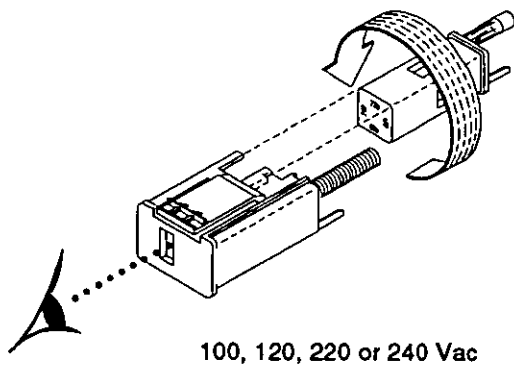

- 4 Replace the fuse-holder assembly in the rear panel.**

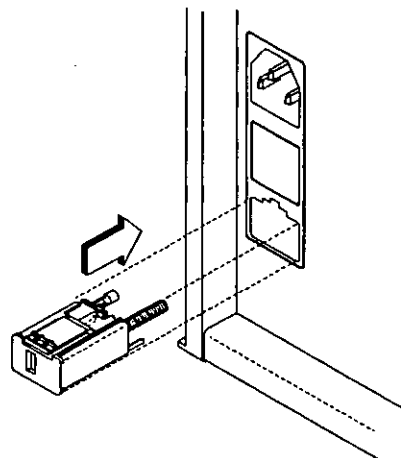

Verify that the correct line voltage appears in the window.

To select the range

You can make measurements using one of 12 voltage ranges available. The voltmeter is capable of measuring true-RMS ac voltages from 100 μV to 300 V.

Caution

When measuring an ac signal superimposed on a dc level, you should always set the range selector switch to the 300 volt position. A high-voltage transient caused by the application of a dc voltage will damage the voltmeter's input circuitry.

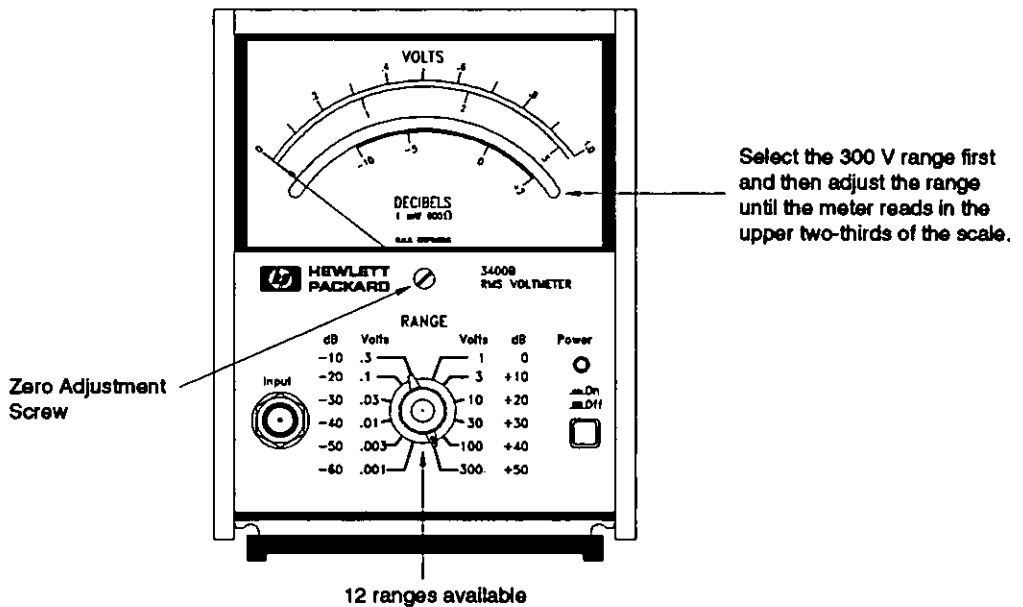

Note The voltmeter may show a zero offset with no voltage applied to the input terminal.

Note If the meter pointer does not indicate "0" when the voltmeter has been turned off for at least one minute, you should adjust the zero screw setting. See chapter 2, "Calibration Procedures," for more information.

To use the DC output signal

You can create plots of measured data and make higher resolution measurements by connecting an X-Y plotter or digital multimeter to the rear-panel DC output jack. On the 1's ranges (0.001, 0.01, 0.1, 1, etc.), the voltage measured at the jack is normalized to -1 Vdc and is proportional to the RMS input voltage (-1 Vdc corresponds to a full-scale meter deflection). On the 3's ranges (0.003, 0.03, 0.3, 3, etc.), the full-scale output is -0.9487 Vdc.

A phone plug for the DC output jack is available by ordering HP part number 1251-0067.

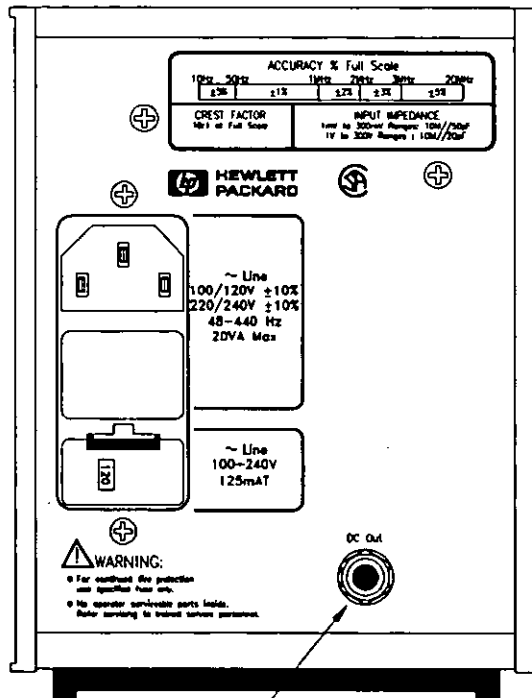

Negative 1 Vdc into open circuit for full scale deflection;
proportional to meter deflection.

1 mA max; nominal source impedance 1 k Ω .

To rack mount the voltmeter

You can mount the voltmeter in a standard 19-inch rack cabinet using one of two optional kits available. If your application requires that you frequently remove the voltmeter from the cabinet, the *combining case* is recommended. You can also use the combining case on the bench to mount the voltmeter with other HP System I instruments. The *rack adapter frame* is recommended for permanent or semi-permanent rack mounting applications.

Remove the front and rear feet before mounting the voltmeter in the combining case or rack adapter frame.

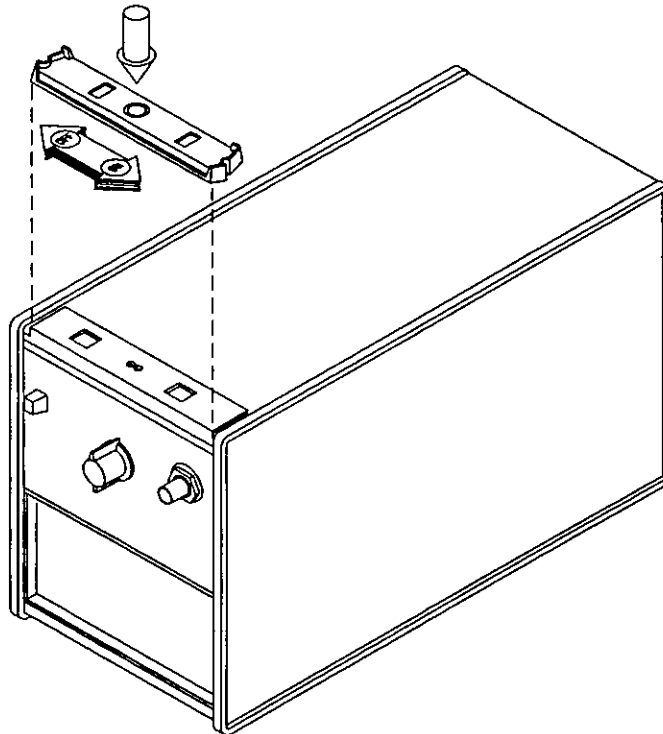

To remove the feet, press down on the release tab and slide to side.

Chapter 1 Quick Start
To rack mount the voltmeter

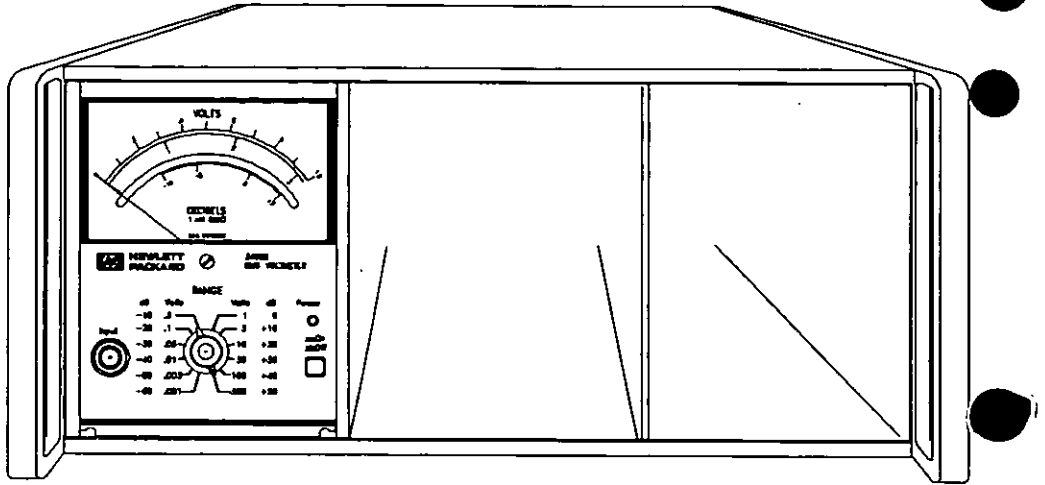

To use the combining case, order part number HP 1052A and rack mount kit 5060-8741.

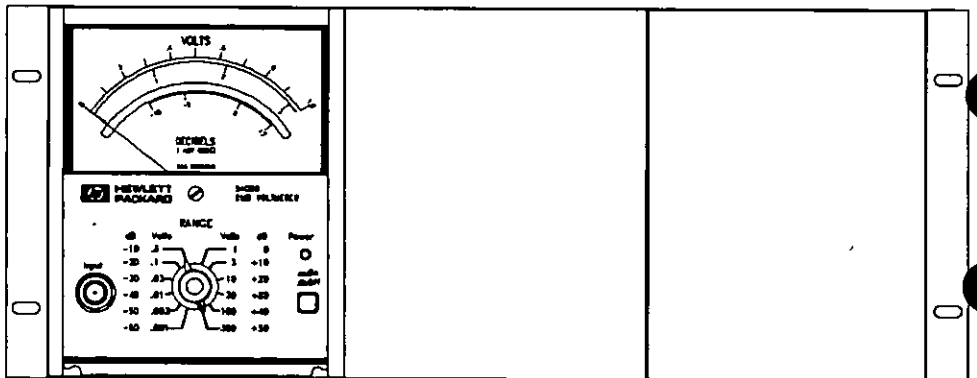

To use the rack adapter frame, order part number HP 5060-8762.

Calibration
Procedures

Calibration Procedures

This chapter contains procedures for performing the voltmeter's verification and adjustment procedures. Notice that the verification procedures are divided into two levels: *Operation Verification* (verifies that the voltmeter meets selected testable specifications) and *Performance Verification* (verifies that the voltmeter meet all testable specifications). The chapter is divided into the following sections:

- Calibration Interval 19
- Time Required for Calibration 19
- Recommended Test Equipment 20
- Test Considerations 20
- Operation Verification Procedures 21
- Performance Verification Procedures 22
- Adjustment Procedures 28
- Test Connector Pinout 36

The verification tests use the voltmeter's specifications listed in "Specifications" on page 4.

Warning

The information in this chapter is for service-trained personnel who are familiar with electronic circuitry and are aware of the hazards involved. To avoid personal injury or damage to the instrument, do not perform procedures in this chapter or do any servicing unless you are qualified to do so.

Some procedures in this chapter must be performed with power applied to the voltmeter while the protective covers are removed. Energy available at many points may, if contacted, result in personal injury.

Caution

Static electricity is a major cause of component failure. To prevent damage to the electrical components in the voltmeter, observe anti-static techniques whenever working on the voltmeter.

Calibration Interval

The voltmeter should be calibrated on a regular interval determined by the measurement accuracy requirements of your application. A 90-day interval is recommended for the most demanding applications, while a 1-year or 2-year interval may be adequate for less demanding applications. Hewlett-Packard does not recommend extending calibration intervals beyond 2 years for any application.

2

Whatever calibration interval you select, Hewlett-Packard recommends that complete re-adjustment should always be performed at the calibration interval. This will increase your confidence that the HP 3400B will remain within specification for the next calibration interval. This criteria for re-adjustment provides the best measure of the voltmeter's long-term stability. Performance data measured using this method can easily be used to extend future calibration intervals.

When your voltmeter is due for calibration, contact your local Hewlett-Packard Service Center for a low-cost recalibration. Calibrations to MIL-STD-45662 are also available at competitive prices.

Time Required for Calibration

The Operation Verification, Performance Verification, and Adjustment procedures in this chapter show you how to manually calibrate the voltmeter. A complete verification and adjustment using these procedures will take approximately one hour.

Recommended Test Equipment

The test equipment recommended for the verification and adjustment procedures is listed below. If the exact instrument is not available, select an equivalent substitute.

Application	Recommended Equipment
Range/Frequency Response Check (page 23, 24)	Fluke 5700A Calibrator, HP 3458A Multimeter
Amplifier Stability Check (page 25)	HP 8161A Pulse Generator, HP 3458A Multimeter
Overload Protection Circuitry Check (page 26)	Fluke 5700A Calibrator, HP 3458A Multimeter
Crest Factor Check (page 27)	HP 8161A Pulse Generator, HP 3458A Multimeter
Front-Panel Meter Zero Adjustment (page 28)	None
Full Scale Gain Adjustment (page 29)	Fluke 5700A Calibrator, HP 3458A Multimeter
Tenth Scale Gain Adjustment (page 30)	Fluke 5700A Calibrator, HP 3458A Multimeter
Full Scale Pointer Adjustment (page 32)	None
20 MHz Flatness Adjustment (page 33)	Fluke 5700A Calibrator, HP 3458A Multimeter
Input Attenuator Adjustment (page 34)	Fluke 5700A Calibrator, HP 3458A Multimeter

Test Considerations

To ensure proper instrument operation, verify that you have selected the correct power line voltage prior to attempting any test procedure in this chapter. See chapter 1, "Quick Start," for more information.

- Assure that the calibration ambient temperature is stable and between 18°C and 28°C.
- Assure that the ambient relative humidity is less than 80%.
- Allow the voltmeter to warm up for 30 minutes, with the covers in place, before attempting any performance checks.

Operation Verification Procedures

The procedures in this section are used to provide a high level of confidence that the voltmeter is meeting published specifications. The Operation Verification test is a subset of the Performance Verification tests and is suitable for checkout after performing repair.

2

The Operation Verification test is performed by completing a partial range/frequency response test as described later in the Performance Verification test procedures. This test verifies the voltmeter's frequency response on the 1 volt range at full scale input levels. The signal measured for this test is a dc voltage taken at the rear-panel dc output jack. This voltage is normalized to -1 Vdc and is proportional to the RMS input voltage (-1 Vdc corresponds to a full-scale meter deflection).

HP 3400B Range	Calibrator Output Voltage	Calibrator Output Frequency	DC Output (DMM Reading)
1 V	1 V	10 Hz	-1.05 V to -0.95 V
1 V	1 V	50 Hz	-1.0075 V to -0.9925 V
1 V	1 V	1 MHz	-1.0075 V to -0.9925 V
1 V	1 V	2 MHz	-1.02 V to -0.98 V
1 V	1 V	3 MHz	-1.03 V to -0.97 V
1 V	1 V	20 MHz	-1.05 V to -0.95 V

- 1 HP 3400B: Select the 1 volt range.
- 2 Calibrator: Select a 1 volt ac signal at 10 Hz (use the "Wideband" output on the Fluke 5700A).
- 3 External Multimeter: Select the 10 Vdc range with 5½ digits of resolution.
- 4 Verify that the dc voltage measured at the rear-panel dc output jack is within the limits shown in the table above.
- 5 Continue checking the dc output as you adjust the calibrator's output voltage and frequency to each of the remaining values shown in the table above.

Performance Verification Procedures

The procedures in this section are used to test the voltmeter's electrical performance using the specifications given on page 4 as the performance standard. You can use these tests for incoming inspection, periodic maintenance, and specification checks after a repair.

Note Allow the voltmeter to warm up for 30 minutes, with the covers in place, before attempting any performance checks.

Range/Frequency Response Check

This test verifies the voltmeter's frequency response on all 12 input voltage ranges. The test is performed both at full scale and tenth scale input levels. The signal measured for this test is a dc voltage taken at the rear-panel dc output jack. On the 1's ranges (0.001, 0.01, 0.1, 1, etc.), this voltage is normalized to -1 Vdc and is proportional to the RMS input voltage (-1 Vdc corresponds to a full-scale meter deflection). On the 3's ranges (0.003, 0.03, 0.3, 3, etc.), the full scale output is -0.9487 Vdc.

Chapter 2 Calibration Procedures
Performance Verification Procedures

Full Scale Test

- 1 HP 3400B: Select the 0.001 volt range.
- 2 Calibrator: Select a 0.001 volt ac signal at 10 Hz.
- 3 External Multimeter: Select the 10 Vdc range with 5½ digits of resolution.
- 4 Verify that the dc voltage measured at the rear-panel dc output jack is within the limits shown in the table below.
- 5 Continue checking the dc output as you adjust the calibrator's output voltage and frequency to each of the remaining values shown in the table below.

2

HP 3400B Range	Calibrator Output Voltage	Calibrator Output Frequency	DC Output (DMM Reading)
0.001 V	0.001 V	10 Hz	-1.05 V to -0.95 V
0.003 V	0.003 V	1 kHz	-0.9558 V to -0.9416 V
0.01 V	0.01 V	1 kHz	-1.0075 V to -0.9925V
0.03 V	0.03 V	1 kHz	-0.9558 V to -0.9416 V
0.1 V	0.1 V	1 kHz	-1.0075 V to -0.9925V
0.3 V	0.3 V	1 kHz	-0.9558 V to -0.9416 V
1 V	1 V	10 Hz	-1.05 V to -0.95 V
1 V	1 V	50 Hz	-1.0075 V to -0.9925 V
1 V	1 V	1 kHz	-1.0075 V to -0.9925 V
1 V	1 V	10 kHz	-1.0075 V to -0.9925 V
1 V	1 V	100 kHz	-1.0075 V to -0.9925 V
1 V	1 V	1 MHz	-1.0075 V to -0.9925 V
1 V	1 V	2 MHz	-1.02 V to -0.98 V
1 V	1 V	3 MHz	-1.03 V to -0.97 V
1 V	1 V	10 MHz	-1.05 V to -0.95 V
1 V	1 V	20 MHz	-1.05 V to -0.95 V
3 V	*3 V	1 kHz	-0.9558 V to -0.9416 V
10 V	*10 V	1 kHz	-1.0075 V to -0.9925V
30 V	*30 V	1 kHz	-0.9558 V to -0.9416 V
100 V	*100 V	1 kHz	-1.0075 V to -0.9925V
300 V	*300 V	1 kHz	-0.9558 V to -0.9416 V

* For all outputs less than 3 volts, use the "Wideband" output on the Fluke 5700A.
 For outputs greater than 3 volts, use the low frequency output.

Chapter 2 Calibration Procedures
Performance Verification Procedures

Tenth Scale Test

- 1 HP 3400B: Select the 1 volt range.
- 2 Calibrator: Select a 0.1 volt ac signal at 10 Hz.
- 3 External Multimeter: Select the 10 Vdc range with 5½ digits of resolution.
- 4 Verify that the dc voltage measured at the rear-panel dc output jack is within the limits shown in the table below.
- 5 Continue checking the dc output as you adjust the calibrator's output voltage and frequency to each of the remaining values shown in the table below.

HP 3400B Range	Calibrator Output Voltage	Calibrator Output Frequency	DC Output (DMM Reading)
1 V	0.1 V	10 Hz	-0.15 V to -0.05 V
1 V	0.1 V	50 Hz	-1.075 V to -0.0925 V
1 V	0.1 V	1 MHz	-1.075 V to -0.0925 V
1 V	0.1 V	2 MHz	-0.12 V to -0.08 V
1 V	0.1 V	3 MHz	-0.13 V to -0.07 V
1 V	0.1 V	10 MHz	-0.15 V to -0.05 V
1 V	0.1 V	20 MHz	-0.15 V to -0.05 V

Amplifier Stability Check

This test verifies the stability of the voltmeter's input amplifier by measuring the rolloff of the frequency response at 40 MHz. The signal measured for this test is a dc voltage taken at the rear-panel dc output jack. This voltage is normalized to -1 Vdc and is proportional to the RMS input voltage (-1 Vdc corresponds to a full-scale meter deflection).

HP 3400B Range	Source Output Voltage	Source Output Frequency	DC Output (DMM Reading)
0.1 V	0.1 V	40 MHz	-0.65 V to -0.45 V

- 1 HP 3400B: Select the 0.1 volt range.
- 2 Source: Select a 0.1 volt ac signal at 40 MHz.
- 3 External Multimeter: Select the 10 Vdc range with 5½ digits of resolution.
- 4 Verify that the dc voltage measured at the rear-panel dc output jack is within the limits shown in the table above.

Overload Protection Circuitry Check

This test verifies the voltmeter's overload protection circuitry by applying a voltage slightly greater than the range limit. The signals measured for this test are dc voltages measured on test connector pin 8 (+VBB) and pin 9 (-VBB). At the end of the overvoltage sequence, the input voltage is returned to 0.1 volts to ensure that the voltmeter will recover to normal operation.

HP 3400B Range	Calibrator Output Voltage	Calibrator Output Frequency	+VBB Reading	-VBB Reading
0.1 V	0.1 V	1 kHz	+11.5 V to +15.5 V	-15.5 V to -11.5 V
0.1 V	0.4 V	1 kHz	+1.0 V to +5.0 V	-5.0 V to -1.0 V

- 1 HP 3400B: Select the 0.1 volt range.
- 2 Calibrator: Select a 0.1 volt ac signal at 1 kHz (use the low frequency output on the Fluke 5700A).
- 3 External Multimeter: Select the 10 Vdc range with 5½ digits of resolution.
- 4 Measure +VBB (pin 8 on the test connector) and -VBB (pin 9 on the test connector). Verify that the measured voltages are within the limits shown in the table above for a 0.1 volt output from the calibrator.
- 5 Increase the calibrator's output voltage from 0.1 volts to 0.4 volts at 1 kHz.
- 6 Measure +VBB and -VBB. Verify that the measured voltages are within the limits shown in the table above for a 0.4 volt output from the calibrator.
- 7 To ensure that the voltmeter will still operate properly, decrease the calibrator's output voltage from 0.4 volts to 0.1 volts.
- 8 Measure +VBB and -VBB. Verify that the measured voltages are within the limits shown in the table above for a 0.1 volt output from the calibrator.

Crest Factor Check

This test verifies the voltmeter's crest factor performance. The signal measured for this test is a dc voltage taken at the rear-panel dc output jack. This voltage is normalized to -0.9487 Vdc and is proportional to the RMS input voltage (-0.9487 Vdc corresponds to a full-scale meter deflection).

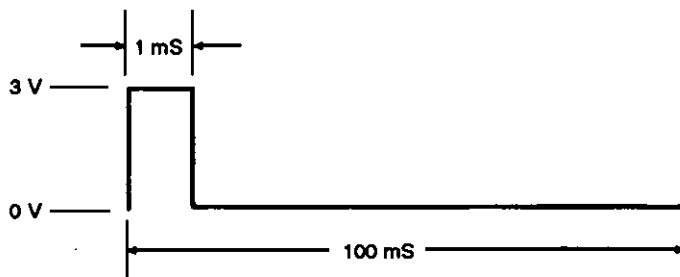

HP 3400B Range	Source Configuration	DC Output (DMM Reading)
0.3 V	Vout=1.5 V, Offset=750 mV, Pulse Output Width=1 mSec, Frequency=10 Hz, Mode=Pulse	-1.05 V to -0.95 V

- 1 HP 3400B: Select the 0.3 volt range.
- 2 Source: Program the source to output a pulse train with the following characteristics: Vout=1.5 volts, offset=750 mV, pulse output width=1 mSec, frequency=10 Hz, mode=pulse.
- 3 External Multimeter: Select the 10 Vdc range with $5\frac{1}{2}$ digits of resolution.
- 4 Verify that the dc voltage measured at the rear-panel dc output jack is within the limits shown in the table above.

Adjustment Procedures

The procedures in this section are used to adjust the voltmeter for peak performance. For best performance, the voltmeter should always be adjusted after repair. Do not perform the adjustment procedures unless they are required. If you make unnecessary adjustments of the internal controls, you may actually cause more difficulty.

Warning

Some procedures in this section must be performed with power applied to the voltmeter while the protective covers are removed. To avoid personal injury or damage to the instrument, do not perform procedures in this section unless you are qualified to do so.

Note Allow the voltmeter to warm up for 30 minutes, with the covers in place, before attempting any adjustments.

Front-Panel Meter Zero Adjustment

The zero adjustment screw is located on the voltmeter's front panel. If the meter pointer does not indicate zero when power has been turned off for at least one minute, adjust the screw setting as described below.

- 1 Turn off the voltmeter and remove any input signals from the front panel and any connections to the rear panel.
- 2 Allow one minute for the meter pointer to stabilize.
- 3 Rotate the zero adjustment screw clockwise until the pointer is to the left of zero on the meter scale. Continue adjusting until the pointer is at zero. *If the pointer overshoots zero, repeat this step.*
- 4 When the pointer is exactly at zero, rotate the adjustment screw slightly counterclockwise to remove tension on the pointer's internal mechanism. *If the pointer moves to the left during this adjustment repeat steps 3 and 4.*

Full Scale Gain Adjustment

This procedure manually adjusts the voltmeter for full scale readings. The full scale adjustment and the tenth scale adjustment (described in the next section) are interdependent and you should repeat the adjustments until both measurements are within the recommended limits.

2

The signal measured for this test is a dc voltage taken at the rear-panel dc output jack. This voltage is normalized to -1 Vdc and is proportional to the RMS input voltage (-1 Vdc corresponds to a full-scale meter deflection).

For this adjustment, all measurements are made on the 0.01 volt range at 1 kHz. You will make the full scale adjustments using R321 which is located on the main circuit board (see below).

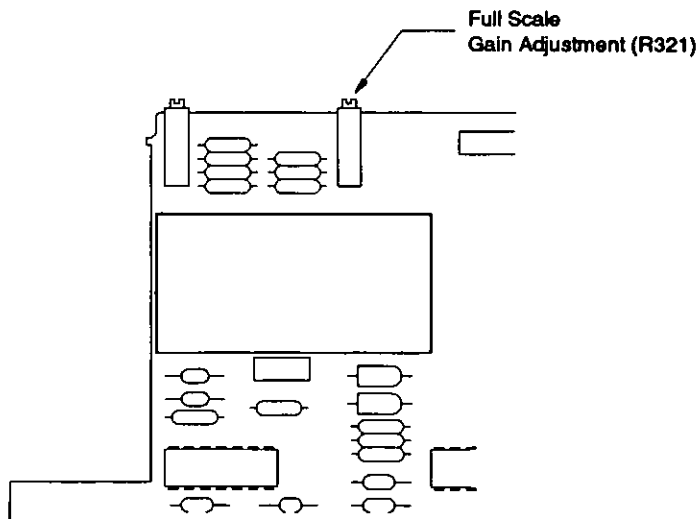

Chapter 2 Calibration Procedures

Adjustment Procedures

HP 3400B Range	Calibrator Output Voltage	Calibrator Output Frequency	DC Output (DMM Reading)
0.01 V	0.01 V	1 kHz	-1.0019 V to -0.9981 V

- 1 HP 3400B: Select the 0.01 volt range.
- 2 Calibrator: Select a 0.01 volt ac signal at 1 kHz (use the "Wideband" output on the Fluke 5700A).
- 3 External Multimeter: Select the 10 Vdc range with 5½ digits of resolution.
- 4 Remove *only* the top cover from the HP 3400B (it is important that you *do not* remove the side or bottom covers). Adjust R321 until the dc voltage measured at the rear-panel dc output jack is within the limits shown in the table above.

Tenth Scale Gain Adjustment

This procedure manually adjusts the voltmeter for tenth scale readings. The tenth scale adjustment and the full scale adjustment (described in the previous section) are interdependent and you should repeat the adjustments until both measurements are within the recommended limits.

The signal measured for this test is a dc voltage taken at the rear-panel dc output jack. This voltage is normalized to -1 Vdc and is proportional to the RMS input voltage (-1 Vdc corresponds to a full-scale meter deflection).

For this adjustment, all measurements are made on the 0.01 volt range at 1 kHz. You will make the tenth scale adjustments using R316 which is located on the main circuit board (see next page).

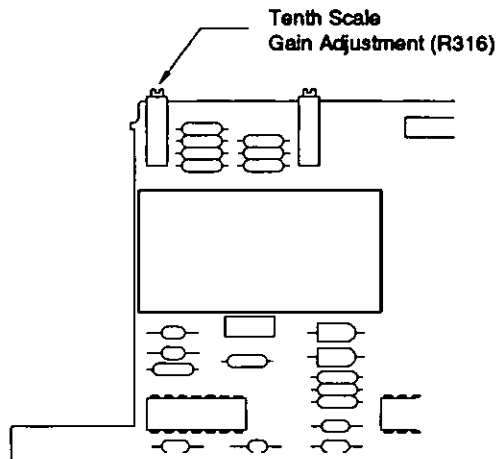

HP 3400B Range	Calibrator Output Voltage	Calibrator Output Frequency	DC Output (DMM Reading)
0.01 V	0.001 V	1 kHz	-0.1019 V to -0.0981 V

- 1 HP 3400B: Select the 0.01 volt range.
- 2 Calibrator: Select a 0.001 volt ac signal at 1 kHz (use the "Wideband" output on the Fluke 5700A).
- 3 External Multimeter: Select the 10 Vdc range with 5½ digits of resolution.
- 4 Remove *only* the top cover from the HP 3400B (it is important that you *do not* remove the side or bottom covers). Adjust R316 until the dc voltage measured at the rear-panel dc output jack is within the limits shown in the table above.

Note Since the full scale and tenth scale adjustments are interdependent, you should repeat both adjustments again. Repeat the procedures again, starting with step 1 for the full scale adjustment, on page 30.

Full Scale Pointer Adjustment

This procedure shows you how to manually adjust the position of the meter pointer for full scale readings. When properly adjusted, the meter pointer should be aligned with the full scale marking on the right side of the meter scale.

This adjustment is made on the 0.1 volt range at 1 kHz. You will use R330 which is located on the main circuit board to make the adjustment (see below).

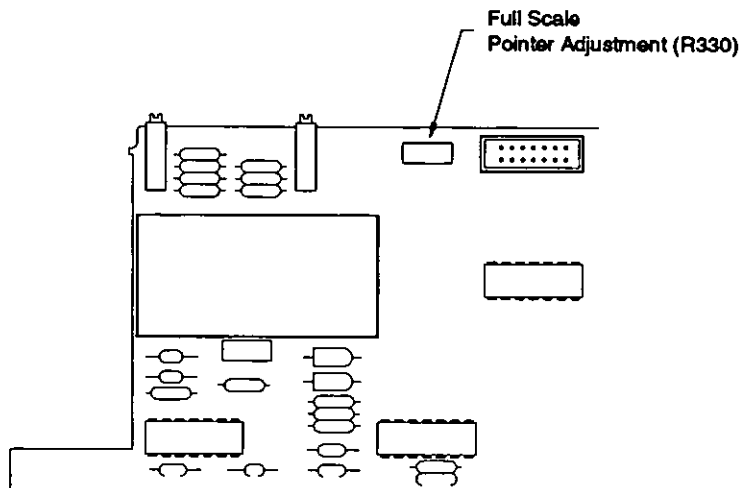

- 1 HP 3400B: Select the 0.1 volt range.
- 2 Calibrator: Select a 0.1 volt ac signal at 1 kHz (use the "Wideband" output on the Fluke 5700A).
- 3 Allow one minute for the meter pointer to stabilize.
- 4 Remove *only* the top cover from the HP 3400B (it is important that you *do not* remove the side or bottom covers). Adjust R330 until the meter pointer is aligned with the full scale marking on the right side of the meter scale.

20 MHz Flatness Adjustment

This procedure manually adjusts the 20 MHz flatness. The adjustment is made with a 100 mV signal applied at 20 MHz. You will make the flatness adjustment using C304 which is located on the main circuit board (see below).

The signal measured for this test is a dc voltage taken at the rear-panel dc output jack. This voltage is normalized to -1 Vdc and is proportional to the RMS input voltage (-1 Vdc corresponds to a full-scale meter deflection).

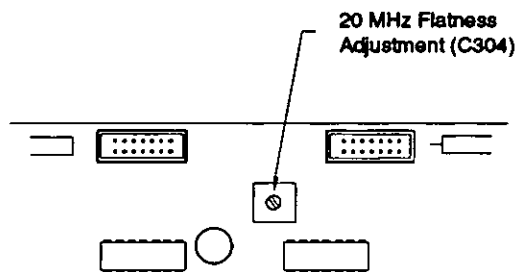

HP 3400B Range	Calibrator Output Voltage	Calibrator Output Frequency	DC Output (DMM Reading)
0.1 V	0.1 V	20 MHz	-1.0125 V to -0.9875 V

- 1 HP 3400B: Select the 0.1 volt range.
- 2 Calibrator: Select a 0.1 volt ac signal at 20 MHz (use the "Wideband" output on the Fluke 5700A).
- 3 External Multimeter: Select the 10 Vdc range with 5½ digits of resolution.
- 4 Remove *only* the right-side cover from the HP 3400B (as viewed from the front panel). It is important that you *do not* remove the left-side, top, or bottom covers. Adjust C304 until the voltage measured at the rear-panel dc output jack is within the limits shown in the table above.

Input Attenuator Adjustment

This procedure performs a manual adjustment of the input attenuator at 50 Hz and 100 kHz. First, you will make the low frequency adjustment at 3V/50 Hz using R123 on the main circuit board (see below). You will make the high frequency adjustment at 3V/100 kHz using C134 on the main circuit board (see below).

The signal measured for this test is a dc voltage taken at the rear-panel dc output jack. This voltage is normalized to -0.9487 Vdc and is proportional to the RMS input voltage (-0.9487 Vdc corresponds to a full-scale meter deflection).

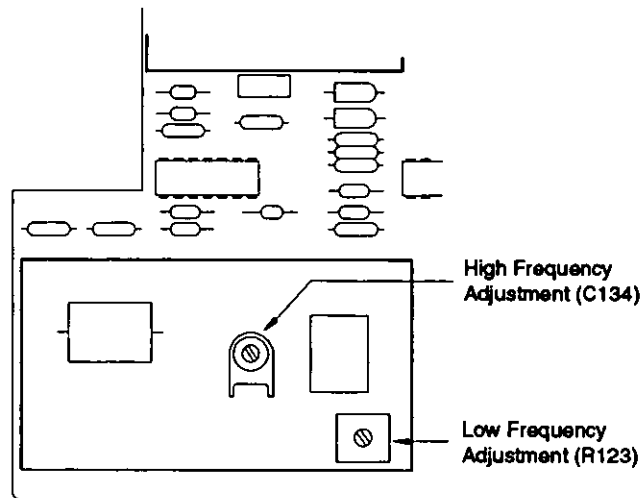

Chapter 2 Calibration Procedures

Adjustment Procedures

HP 3400B Range	Calibrator Output Voltage	Calibrator Output Frequency	DC Output (DMM Reading)
3 V	3 V	50 Hz	-0.950 V to -0.947 V
3 V	3 V	100 kHz	-0.950 V to -0.947 V

2

Low Frequency

- 1 HP 3400B: Select the 3 volt range.
- 2 Calibrator: Select a 3 volt ac signal at 50 Hz (use the "Wideband" output on the Fluke 5700A).
- 3 External Multimeter: Select the 10 Vdc range with 5½ digits of resolution.
- 4 Remove *only* the right-side cover from the HP 3400B (as viewed from the front panel). It is important that you *do not* remove the left-side, top, or bottom covers. Adjust R123 until the voltage measured at the rear-panel dc output jack is within the limits shown in the table above for 50 Hz.

High Frequency

- 1 HP 3400B: Select the 3 volt range.
- 2 Calibrator: Select a 3 volt ac signal at 100 kHz (use the "Wideband" output on the Fluke 5700A).
- 3 External Multimeter: Select the 10 Vdc range with 5½ digits of resolution.
- 4 Remove *only* the right-side cover from the HP 3400B (as viewed from the front panel). It is important that you *do not* remove the left-side, top, or bottom covers. Adjust C134 until the voltage measured at the rear-panel dc output jack is within the limits shown in the table above for 100 kHz.

Test Connector Pinout

Test connector J3 gives you access to several test points on the main circuit board. You can build your own custom ribbon cable interface if is convenient for your application. The table below shows the pinout for the test connector. *Refer to the schematics in chapter 7 for more detailed information on the circuitry that interfaces with the test connector.*

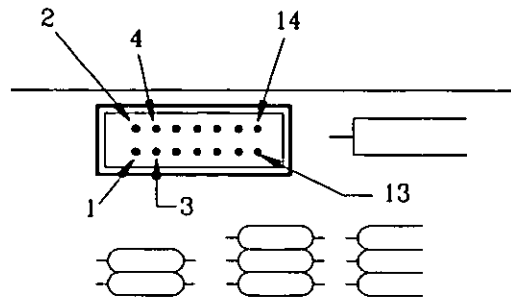

Test Connector J3

Pin Number	Description
1	K101B, Relay Drive Logic for Relay K101 (low true, see the table on page 45).
2	K201B, Relay Drive Logic for Relay K201 (low true, see the table on page 45).
3	K202B, Relay Drive Logic for Relay K202 (low true, see the table on page 45).
4	K203B, Relay Drive Logic for Relay K203 (low true, see the table on page 45).
5	Remote/Local Control, Ground or Hold Low to Disable Range Selector Switch.
6	+VCC (4.7 kΩ Series Resistor).
7	CGND, Common Ground
8	+VBB
9	-VBB
10	-VRAW (10 kΩ Series Resistor), Output from Power Transformer (T1).
11	Not Used
12	OPAMP_DC, Output from Wideband Amplifier (U301).
13	DC_OUT, Same as Rear Panel Output (loading on this line will affect signal on rear-panel output; loading on rear-panel output will affect signal on this line).
14	CGND, Common Ground

Theory of
Operation

Theory of Operation

This chapter is organized to provide descriptions of the circuitry contained on each schematic shown in chapter 7. A block diagram overview is provided followed by more detailed descriptions of the circuitry contained in the schematics chapter.

- Block Diagram 39
- Input Attenuator 41
- Impedance Converter 41
- Post Attenuator 42
- Wideband Amplifier 42
- Chopper Op Amp / Thermocouple Pair 43
- Power Supplies 44
- Switch Board 45

Block Diagram

Referring to the instrument block diagram shown below, you can see that the voltmeter's operational circuitry consists of two attenuators, an impedance converter, a wideband amplifier, a chopper op amp, a thermocouple pair, and a direct reading meter.

3

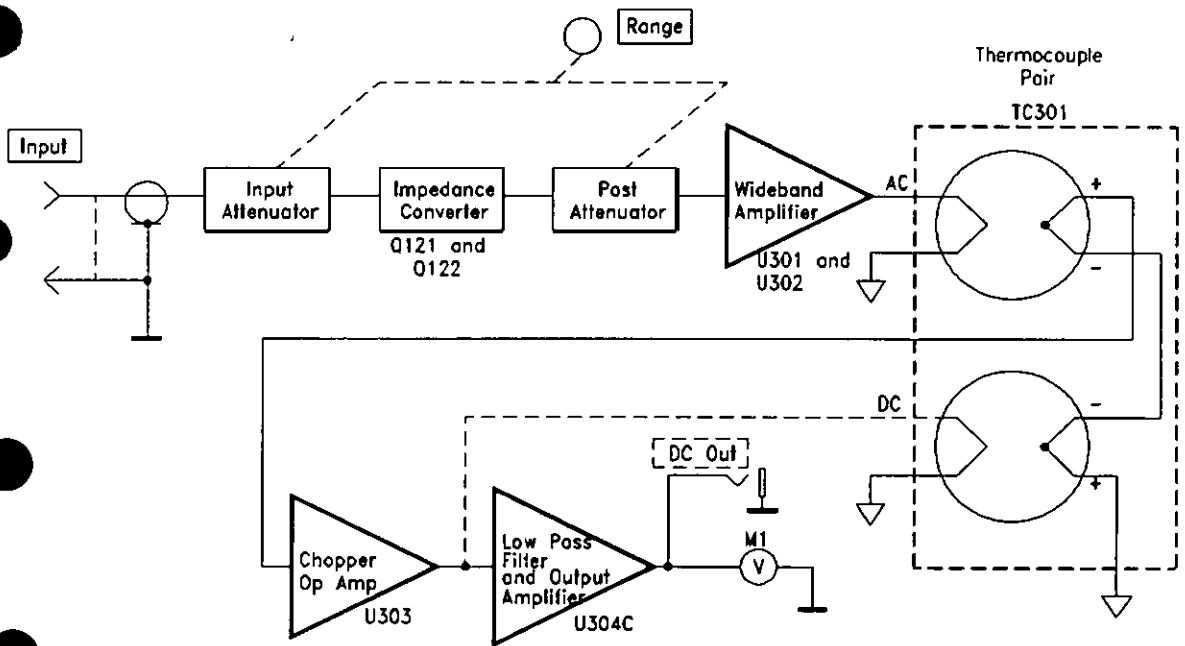

HP 3400B Block Diagram

Chapter 3 Theory of Operation

Block Diagram

A signal being measured is applied to the input attenuator through the input connector, located on the voltmeter's front panel. The input attenuator has an input impedance of $10\text{ M}\Omega$ and provides two ranges of attenuation. The output of the input attenuator is applied to the impedance converter. The impedance converter is a non-inverting unity voltage gain amplifier. It presents a high impedance to the input signal and provides a low impedance output to drive the post attenuator. The post attenuator provides six ranges in a 1, 3, 10 sequence. The two attenuators are switched to provide 12 ranges of attenuation.

The output of the post attenuator is amplified by the wideband amplifier. The wideband amplifier is a two-stage amplifier (U301 and U302). The ac output of the wideband amplifier is amplified to drive one of the thermocouples in the thermocouple pair (TC301).

The dc output of TC301 is applied to the chopper op amp (U303) which modulates the voltage. The resultant modulated signal is then amplified and, after the amplification, the signal is demodulated back to a dc voltage. This voltage is the output of the chopper op amp. The value of the voltage is proportional to the dc input voltage.

The output of the chopper op amp is applied to a filter and also to the second thermocouple of the thermocouple pair (TC301). The output of the filter is applied to a dc output amplifier (U304C) which is used to drive the meter (M1).

The thermocouple pair (TC301) acts as a summing point for the ac output of the wideband amplifier and the dc output of the chopper op amp. The difference in the heating effect of these voltages is the dc input to the chopper op amp. This difference input is amplified and is fed to TC301 and also, after going through the output amplifier (U304C), to the meter (M1). This voltage represents the RMS value of the ac signal applied to the input connector. By using a "matched" thermocouple pair and measuring the difference, the output of the chopper op amp will be linear. Using a matched thermocouple pair also provides temperature stability.

Input Attenuator

The input attenuator is a capacitive-compensated attenuator which provides two ranges of attenuation for the 12 positions of the Range selector switch. When the selector switch is positioned to one of the six most sensitive ranges (1 mV to 300 mV), the attenuator output voltage is equal to the input voltage. When the selector switch is positioned to one of the six higher ranges (1 V to 300 V), the input signal is attenuated 60 dB (1000:1 voltage division) by the resistive voltage divider consisting of R121, R122, and R123. Trimmer C134 is adjusted at 100 kHz, and R123 is adjusted at 50 Hz to provide constant attenuation over the input frequency range.

3

Impedance Converter

The impedance converter uses a FET-follower circuit to match the high output impedance of the input attenuator to the low input impedance of the post attenuator. The FET-follower circuitry has unity gain with no phase inversion between the input and output signals.

The ac input signal to the impedance converter is resistor/capacitor coupled via R127 and C149 to the gate of FET Q121. The output of the converter is developed across Q122 which acts like a variable load resistor for the FET.

The bootstrap circuitry, consisting of C152 and R130, increases the input impedance of the converter circuitry and the compensating feedback circuitry, consisting of C151, decreases the output impedance of the converter. The bias voltage for Q122 is developed by resistors R133, CR125, R134, and R140.

Post Attenuator

The post attenuator is a resistive divider which attenuates the ac input signal while maintaining a low impedance output for the following amplification stages. The ac input signal is applied to a precision resistive voltage divider. These resistors are arranged to give six ranges of attenuation at 10 dB per range. The six ranges of the post attenuator combined with the two ranges of the input attenuator make up the 12 ranges of attenuation (1 mV to 300 V).

Wideband Amplifier

The wideband amplifier provides constant gain to the ac signal being measured over the entire frequency range of the HP 3400B. The wideband amplification required to drive the thermocouple heater is provided in two gain stages. The first stage has a gain of 36 dB and consists of a differential transistor pair Q301 and Q302 driving U301. This gain stage also includes the capacitor feedback adjustment (C304) to adjust the voltmeter's frequency response at 20 MHz. The second stage has a gain of 14 dB to the thermocouple heater and consists of U302.

The combined gain of 50 dB amplifies the 1 mV RMS full-scale input signal to 316 mV RMS applied to the thermocouple heater. The nominal resistance of the heater is 90 Ω and there is 3.5 mA RMS of current flowing at full-scale input signal.

Protection against excess current to the thermocouple heater is provided by controlling the power supply voltages to the heater drive op amp (U302). The output from U302 is peak-detected by CR306 and CR307 and is then averaged with an RC network. The average dc level is compared with a reference by comparators U304A and U304B. The comparator output lowers the supply voltage via Q303 and Q304 when the average dc level exceeds the reference level. The average dc level of the input signal allows for 10-to-1 crest factor signals to be applied to the heater at proper levels without being attenuated.

Chopper Op Amp / Thermocouple Pair

The chopper op amp and the thermocouple pair form a servo loop which functions to position the direct reading meter (M1) to the RMS value of the ac input signal. The wideband amplifier output is applied to the heater of thermocouple pair (TC301). The ac voltage causes a dc voltage to be generated in the resistive portion of TC301 which is proportional to the heating effect (RMS value) of the ac input. The dc voltage is applied to the chopper op amp.

The chopper op amp circuitry consists of a chopper op amp (U303), filter, and output amplifier (U304C). The chopper op amp is a high-gain, low-drift op amp and is used to modulate the applied dc voltage, amplify the voltage, and then demodulate the voltage back to a dc voltage (the output voltage of the amplifier). The output of the amplifier is the ac stabilizing and summing feedback for the thermocouple pair (TC301), and is also applied to the filter. The ac stabilizing feedback (using R323, R320, and C309) is used to prevent the circuitry from oscillating.

The output from the chopper op amp (summing feedback) is applied to the heating element of thermocouple pair (TC301). The dc voltage developed in the resistive portion of TC301 is effectively subtracted from the voltage developed by TC301. The input signal to the chopper op amp then becomes the difference in the dc outputs of the two thermocouples. When the difference between the two thermocouples becomes zero, the dc output from the chopper op amp will be equal to the ac output from the wideband amplifier.

The low pass filter, consisting of R325, R326, C312, C313, and U304C, is used to further reduce the noise on the output of the chopper op amp. This is to make the meter reading quiet.

The output of the low pass filter and output amplifier (U304C) drives the meter (M1) and the DC Out connector on the rear panel. The rear terminal's output impedance is approximately 1000 Ω .

Power Supplies

The power supplies provide dc operating voltages for the circuitry used in the HP 3400B. The input line power is applied to an input line module. The module contains a line filter, a fuse, the line switch, and voltage tap selection for the power transformer. Four line voltage selections are available: 100, 120, 220, 240 Vac.

The outputs from the power transformer drive three voltage regulators. The voltages produced by the three voltage regulators are: +27 Vdc, -15 Vdc, and +5 Vdc. The +27 Vdc supply is used to power the impedance converter Q121 and Q122. The +27 Vdc supply is also dropped by a 12 volt zener diode (CR112) to develop +15 Vdc for U302 through overload regulator Q303. In addition, the +27 Vdc supply is regulated by a 15 volt zener diode (CR111) for U301 and U304. The dc chopper amplifier is powered by temperature-compensated 6.2 volt zener diodes (CR113 and CR114) to provide a stable dc source to U303 and its associated circuits. The +5 Vdc supply is used to power the logic circuitry and attenuator relays.

Switch Board

The switch control circuitry is located on the small circuit board which is connected to the front-panel Range selector switch. The Schottky diodes (CR41 through CR60) on the switch board provide the appropriate relay logic for the relay drivers on the main circuit board (see table below). The switch board connects to the main circuit board using a ribbon cable (P1). The switch board also provides the interface for wiring to the meter mechanism, the front-panel power LED, and the rear-panel DC Out connector.

3

Voltage Range	K101	K201	K202 and K204	K203
0.001	0	0	0	1
0.003	0	1	0	1
0.01	0	0	0	0
0.03	0	1	0	0
0.1	0	0	1	1
0.3	0	0	1	0
1.0	1	0	0	1
3.0	1	1	0	1
10.0	1	0	0	0
30.0	1	1	0	0
100.0	1	0	1	1
300.0	1	0	1	0

0 = Relay De-Energized; 1 = Relay Energized.

()



Service



Service

This chapter discusses the procedures involved for returning a failed voltmeter to Hewlett-Packard for service or repair. Subjects covered include the following:

- Operating Checklist 49
- To Replace the Power-Line Fuse 49
- Repackaging for Shipment 50
- Electrostatic Discharge (ESD) Precautions 50

Operating Checklist

Before returning your voltmeter to Hewlett-Packard for service or repair, check the following items:

- Verify that the ac power cord is connected to the voltmeter.
- Verify that the front-panel **Power** switch is depressed.
- Verify that the power-line fuse is good.
Use a 125 mAT, 250 V fuse for 100, 120, 220 or 240 Vac operation.
- Verify the power-line voltage setting.
See "To prepare the voltmeter for use" on page 11.

4

To Replace the Power-Line Fuse

The power-line fuse is located within the voltmeter's fuse-holder assembly on the rear panel (see page 12). A 125 mAT slow-blow fuse (HP part number 2110-0894) is installed when the voltmeter is shipped from the factory. This is the correct power-line fuse for 100, 120 220, or 240 Vac operation.

Repackaging for Shipment

If the instrument is to be shipped to HP for service or repair, be sure to:

- Attach a tag to the voltmeter identifying the owner and indicating the required service or repair. Include the instrument model number and full serial number.
- Place the voltmeter in its original container with appropriate packaging material.
- Secure the container with strong tape or metal bands.

If the original shipping container is not available, place your unit in a container which will ensure at least 4 inches of compressible packaging material around all sides for the voltmeter. Use static-free packaging materials to avoid additional damage to your unit. *HP suggests that you always insure shipments.*

Electrostatic Discharge (ESD) Precautions

Almost all electrical components can be damaged by electrostatic discharge (ESD) during handling. Component damage can occur at electrostatic discharge voltages as low as 50 volts.

The following guidelines will help prevent ESD damage when servicing the voltmeter or any electronic device.

- Disassemble instruments *only* in a static-free work area.
 - Use a conductive work area to dissipate static charge.
 - Use a conductive wrist strap to dissipate static charge accumulation.
 - Minimize handling.
 - Keep replacement parts in original static-free packaging.
 - Remove all plastic, styrofoam, vinyl, paper, and other static-generating materials from the immediate work area.
-

Replaceable
Parts

Replaceable Parts

This section contains information for ordering replacement parts for your HP 3400B Voltmeter. Parts are listed in the alphanumeric order according to their schematic reference designators. The parts lists include a brief description of the part with the applicable HP part number and manufacturer part number. The total quantity of a part is given the first time the part number appears.

To Order Replaceable Parts

You can order replaceable parts from HP or directly from the manufacturer using the manufacturer's part number in the replaceable parts list. To order replaceable parts from HP, do the following:

- 1 Contact your nearest HP Sales Office or HP Service Center.
- 2 Identify parts by their HP part number shown in the replaceable parts lists.
- 3 Provide the instrument model number and serial number.

Backdating and Part Changes

Always refer to chapter 6, "Backdating," before attempting repair or before ordering replacement parts. Parts changes are documented in the backdating chapter.

■ Replaceable Parts: 03400-66522 – Main PC Assembly

Reference Designation	HP Part Number	Qty	Part Description	Mfr. Code	Mfr. Part Number
A1C101	0180-3925	2	Capacitor-Fxd 470 uF ± 20% 100 V	28480	0180-3925
A1C102	0180-4129	3	Capacitor-Fxd 1 uF ± 10% 35 V	56289	173D105X9035V
A1C103	0160-4835	15	Capacitor-Fxd 0.1 uF ± 10% 50 V	04222	SA105C104KAAH
A1C104	0180-3868	1	Capacitor-Fxd 220 uF ± 20% 35 V	28480	0180-3868
A1C105	0180-4129		Capacitor-Fxd 1 uF ± 10% 35 V	56289	173D105X9035V
A1C106	0180-3876	1	Capacitor-Fxd 1000 uF ± 20% 25 V	28480	0180-3876
A1C107	0180-4129		Capacitor-Fxd 1 uF ± 10% 35 V	56289	173D105X9035V
A1C108	0180-4130	4	Capacitor-Fxd 2.2 uF ± 10% 20 V	56289	173D225X9020V
A1C121	0170-0022	1	Capacitor-Fxd 0.1 uF ± 20% 600 V	28480	0170-0022
A1C129-C133	0160-5350	12	Capacitor-Fxd 300 pF ± 5% 100 V	04222	SA101A301JAAH
A1C134	0121-0560	1	Capacitor-Variable 0.8 pF to 5 pF 500V	18736	V3246
A1C135-C141	0160-5350		Capacitor-Fxd 300 pF ± 5% 100 V	04222	SA101A301JAAH
A1C144-C146	0160-4832	4	Capacitor-Fxd 0.01 uF ± 10% 100 V	04222	SA101C103KAAH
A1C148	0160-4819	1	Capacitor-Fxd 2200 pF ± 5% 100 V	04222	SA301A222JAAH
A1C149	0160-0168	1	Capacitor-Fxd 0.1 uF ± 10% 200 V	09023	WMC2P1
A1C150	0180-3925		Capacitor-Fxd 470 uF ± 20% 100 V	28480	0180-3925
A1C151	0180-4133	1	Capacitor-Fxd 15 uF ± 10% 20 V	56289	173D156X9020X
A1C152	0180-4130	3	Capacitor-Fxd 2.2 uF ± 10% 20 V	56289	173D225X9020V
A1C153-C154	0180-3829	4	Capacitor-Fxd 220 uF ± 20% 16 V	28480	0180-3829
A1C155	0180-4135	2	Capacitor-Fxd 33 uF ± 10% 10 V	56289	173D336X9010X
A1C315	0180-4136	4	Capacitor-Fxd 10 uF ± 10% 20 V	56289	173D106X9020W
A1C201	0160-4791	1	Capacitor-Fxd 10 pF ± 10% 100 V	04222	SA102A100JAAH
A1C202-C205	0160-5896	5	Capacitor-Fxd 1 pF ± 25% 100 V	28480	0160-5896
A1C206	0160-4804	1	Capacitor-Fxd 56 pF ± 5% 100 V	04222	SA102A560JAAH
A1C207-C208	0160-4800	2	Capacitor-Fxd 120 pF ± 5% 100 V	04222	SA102A121JAAH
A1C209-C213	0160-4835		Capacitor-Fxd 0.1 uF ± 10% 50 V	04222	SA105C104KAAH
A1C301	0160-4835		Capacitor-Fxd 0.1 uF ± 10% 50 V	04222	SA105C104KAAH
A1C302	0180-4135		Capacitor-Fxd 33 uF ± 10% 10 V	56289	173D336X9010X
A1C303	0160-4383	1	Capacitor-Fxd 6.8 pF ± 7.35% 200 V	04222	SR156A6R8DAA
A1C304	0121-0451	1	Capacitor-Variable 1.7pF to 11pF 175V	74970	187-0106-028
A1C305	0160-4835		Capacitor-Fxd 0.1 uF ± 10% 50 V	04222	SA105C104KAAH
A1C306	0180-3829		Capacitor-Fxd 220 uF ± 20% 16 V	28480	0180-3829
A1C307	0160-4832		Capacitor-Fxd 0.01 uF ± 10% 100 V	04222	SA101C103KAAH
A1C308	0160-5896		Capacitor-Fxd 1 pF ± 25% 100 V	28480	0160-5896
A1C309	0160-6207	1	Capacitor-Fxd 1 uF ± 5% 50 V	28480	0160-6207
A1C310-C311	0160-4835		Capacitor-Fxd 0.1 uF 10% 50 V	04222	SA105C104KAAH
A1C312-C313	0160-4844	4	Capacitor-Fxd 1 uF +80% -20% 50 V	04222	SA305E105ZAA
A1C314	0180-4130		Capacitor-Fxd 2.2 uF ± 10% 20 V	56289	173D225X9020V
A1C315	0180-4136		Capacitor-Fxd 10 uF ± 10% 20 V	56289	173D106X9020W
A1C316	0160-4844		Capacitor-Fxd 1 uF +80% -20% 50 V	04222	SA305E105ZAA
A1C317	0160-4835		Capacitor-Fxd 0.1 uF ± 10% 50 V	04222	SA105C104KAAH
A1C318	0180-4130		Capacitor-Fxd 2.2 uF ± 10% 20 V	56289	173D225X9020V
A1C319	0180-4136		Capacitor-Fxd 10 uF ± 10% 20 V	56289	173D106X9020W

Chapter 5 Replaceable Parts

03400-66522 Replaceable Parts (continued)

Reference Designation	HP Part Number	Qty	Part Description	Mfr. Code	Mfr. Part Number
A1C320	0160-4844		Capacitor-Fxd 1 uF +80% -20% 50 V	04222	SA305E105ZAA
A1C321	0160-4835		Capacitor-Fxd 0.1 uF ± 10% 50 V	04222	SA105C104KAAH
A1C322	0180-4136		Capacitor-Fxd 10 uF ± 10% 20 V	56289	173D106X9020W
A1C323-C324	0160-4835		Capacitor-Fxd 0.1 uF ± 10% 50 V	04222	SA105C104KAAH
A1C325	0180-3829		Capacitor-Fxd 220 uF ± 20% 16 V	28480	0180-3829
A1C326	0180-4134	1	Capacitor-Fxd 22 uF ± 10% 15 V	56289	173D226X9015X
A1C327	0160-5888	1	Capacitor-Fxd 24 pF ± 5% 100 V	04222	SA102A240JAAH
A1C328	0160-4808	1	Capacitor-Fxd 470 pF ± 5% 100 V	04222	SA101A471JAAH
A1C329	0160-4835		Capacitor-Fxd 0.1 uF ± 10% 50 V	04222	SA105C104KAAH
A1CR101-CR110	1901-0743	13	Diode-Power Rectifier 400 V 1A	71744	1N4004
A1CR111	1902-0962	2	Diode-Zener 15V 5% PD=.4 W IR=5 uA	04713	SZ30035-2
A1CR112	1902-0029	1	Diode-Zener 12V 5% PD=1W IR=5 uA	04713	1N4742ARL
A1CR113-CR114	1902-0777	2	Diode-Zener 6.2V 5% PD=0.4W	04713	1N825
A1CR121	1901-0050	4	Diode-Switching 80V 200 mA 2 nS	28480	1901-0050
A1CR122	1902-0962		Diode-Zener 15V 5% PD=.4 W IR=5 uA	04713	SZ30035-2
A1CR123	1901-0050		Diode-Switching 80 V 200 mA 2 nS	28480	1901-0050
A1CR124-CR125	1901-1098	10	Diode-Switching 50 V 200 mA 4 nS	27014	1N4150
A1CR126-CR128	1901-0743		Diode-Power Rectifier 400 V 1A	71744	1N4004
A1CR129-CR130	1901-0050		Diode-Switching 80V 200 mA 2 nS	28480	1901-0050
A1CR201-CR205	1901-1098		Diode-Switching 50 V 200 mA 4 nS	27014	1N4150
A1CR301	1901-1098		Diode-Switching 50 V 200 mA 4 nS	27014	1N4150
A1CR302-CR303	1901-0025	2	Diode-General Purpose 100 V 200 mA	28480	1901-0025
A1CR304-CR305	1901-1098		Diode-Switching 50 V 200 mA 4 nS	27014	1N4150
A1CR306-CR307	1901-0518	2	Diode-Schottky Small Signal	28480	1901-0518
A1HS101-HS103	1205-0355	3	Heat Sink Single TO-220-Case	13103	6043PB
A1J1	1250-1842	1	Connector-RF BNC Rcpt PC-W-Stdfs 50Ω	00779	227677-1
A1J2-J3	1251-8823	2	Connector-Post Type 0.100-Spcg 14-Contact	76381	2514-6002UB
A1J4	1252-4488	1	Connector-Post Type 0.156-Spcg 8-Contact	27264	26-64-4080
A1K101	0490-1774	1	Relay 1C 5 Vdc-Coil 3A 250 Vac	28480	0490-1774
A1K201-K204	0490-1638	4	Relay 2C 5 Vdc-Coil 1A 125 Vac	28480	0490-1638
A1MP5-MP7	0380-0741	3	Standoff-Rvt-On 0.187-In-Lg 6-32-Thd	05791	MK6910-3/16-2-14
A1MP9	0590-1054	1	Threaded Insert-Nut 6-32 .065-In-Lg SST	46384	KFS2-632
A1PCB1	03400-26522	1	PC Board - Blank	28480	03400-26522
A1Q121	1855-0386	1	Transistor J-FET N-Chan D-Mode	04713	2N4392
A1Q122	1854-1114	1	Transistor NPN Si TO-39 PD=3.5W FT=1GHz	04713	MRF544
A1Q301-Q302	1854-0795	2	Transistor NPN Si PD=625 mW FT=650 MHz	04713	MPSH10
A1Q303	1854-1028	1	Transistor NPN Si PD=350 mW FT=300MHz	04713	2N3904
A1Q304	1853-0563	1	Transistor PD=310 mW FT=250 MHz	04713	2N3906 (SEL)

Chapter 5 Replaceable Parts

03400-66522 Replaceable Parts (continued)

Reference Designation	HP Part Number	Qty	Part Description	Mfr. Code	Mfr. Part Number
A1R101	0698-4421	2	Resistor 249 \pm 1% .125W TF TC = 0 \pm 100	24546	CT4-1/8-T0-249R-F
A1R102	0757-0438	1	Resistor 5.11K \pm 1% .125W TF TC = 0 \pm 100	24546	CT4-1/8-T0-5111-F
A1R103	0698-4408	1	Resistor 124 \pm 1% .125W TF TC = 0 \pm 100	24546	CT4-1/8-T0-124R-F
A1R104	0698-4423	1	Resistor 1.37K \pm 1% .125W TF TC = 0 \pm 100	24546	CT4-1/8-T0-1371-F
A1R105	0698-4421	1	Resistor 249 \pm 1% .125W TF TC = 0 \pm 100	24546	CT4-1/8-T0-249R-F
A1R106	0757-0420	2	Resistor 750 \pm 1% .125W TF TC = 0 \pm 100	24546	CT4-1/8-T0-751-F
A1R107	0698-3634	1	Resistor 470 \pm 5% 2W MO TC = 0 \pm 200	28480	0698-3634
A1R108	0764-0042	1	Resistor 2.2K \pm 5% 2W MO TC = 0 \pm 200	28480	0764-0042
A1R109	0698-3635	1	Resistor 680 \pm 5% 2W MO TC = 0 \pm 200	28480	0698-3635
A1R110	0757-0442	6	Resistor 10K \pm 1% .125W TF TC = 0 \pm 100	24546	CT4-1/8-T0-1002-F
A1R121	0698-4128	1	Resistor 10M \pm 0.25% 1W TF TC = 0 \pm 50	03888	A3AH87
A1R122	0698-6204	1	Resistor 9.9K \pm 1% .125W TF TC = 0 \pm 100	24546	CT4-1/8-T0-9901-F
A1R123	2100-3212	1	Resistor-Trim 200 10% TKF Top Adj 1-Turn	32997	3386P-Y46-201
A1R124	0757-0346	3	Resistor 10 \pm 1% .125W TF TC = 0 \pm 100	28480	0757-0346
A1R126	0757-0410	4	Resistor 301 \pm 1% .125W TF TC = 0 \pm 100	24546	CT4-1/8-T0-301R-F
A1R127	0764-0043	1	Resistor 2.7K \pm 5% 2W MO TC = 0 \pm 200	28480	0764-0043
A1R128	0757-0401	2	Resistor 100 \pm 1% .125W TF TC = 0 \pm 100	24546	CT4-1/8-T0-101-F
A1R129	0757-0472	2	Resistor 200K \pm 1% .125W TF TC = 0 \pm 100	24546	CT4-1/8-T0-2003-F
A1R130	0683-3355	1	Res 3.3M \pm 5% .25W CC TC = -900/+1100	01121	CB3355
A1R131	0757-0462	1	Resistor 75K \pm 1% .125W TF TC = 0 \pm 100	24546	CT4-1/8-T0-7502-F
A1R132	0698-3488	1	Resistor 442 \pm 1% .125W TF TC = 0 \pm 100	24546	CT4-1/8-T0-422R-F
A1R133	0698-3150	1	Resistor 2.37K \pm 1% .125W TF TC = 0 \pm 100	24546	CT4-1/8-T0-2371-F
A1R135	0698-4486	1	Resistor 24.9K \pm 1% .125W TF TC = 0 \pm 100	24546	CT4-1/8-T0-2492-F
A1R134	0757-0280	5	Resistor 1K \pm 1% .125W TF TC = 0 \pm 100	24546	CT4-1/8-T0-1001-F
A1R136	0757-0277	4	Resistor 49.9 \pm 1% .125W TF TC = 0 \pm 100	28480	0757-0277
A1R137-R138	0757-0384	5	Resistor 20 \pm 1% .125W TF TC = 0 \pm 100	19701	5033R-1/8-T0-20R0-F
A1R139	0757-0381	2	Resistor 15 \pm 1% .125W TF TC = 0 \pm 100	19701	5033R-1/8-T0-15R0-F
A1R140	0757-0283	1	Resistor 2K \pm 1% .125W TF TC = 0 \pm 100	24546	CT4-1/8-T0-2001-F
A1R201	0757-0277	1	Resistor 49.9 \pm 1% .125W TF TC = 0 \pm 100	28480	0757-0277
A1R202-R203	0698-4123	3	Resistor 499 \pm 1% .125W TF TC = 0 \pm 100	24546	CT4-1/8-T0-499R-F
A1R204	0698-6323	5	Resistor 100 \pm 0.1% .125W TF TC = 0 \pm 25	28480	0698-6323
A1R205	0698-6774	5	Resistor 150 \pm 0.1% .125W TF TC = 0 \pm 25	28480	0698-6774
A1R206	0698-4476	3	Resistor 10.2K \pm 1% .125W TF TC = 0 \pm 100	24546	CT4-1/8-T0-1022-F
A1R207	0698-6323	1	Resistor 100 \pm 0.1% .125W TF TC = 0 \pm 25	28480	0698-6323
A1R208	0698-6774	1	Resistor 150 \pm 0.1% .125W TF TC = 0 \pm 25	28480	0698-6774
A1R209	0698-4477	2	Resistor 10.5K \pm 1% .125W TF TC = 0 \pm 100	24546	CT4-1/8-T0-1052-F
A1R210	0698-6323	1	Resistor 100 \pm 0.1% .125W TF TC = 0 \pm 25	28480	0698-6323
A1R211	0698-6774	1	Resistor 150 \pm 0.1% .125W TF TC = 0 \pm 25	28480	0698-6774
A1R212	0698-4476	1	Resistor 10.2K \pm 1% .125W TF TC = 0 \pm 100	24546	CT4-1/8-T0-1022-F
A1R213	0698-6323	1	Resistor 100 \pm 0.1% .125W TF TC = 0 \pm 25	28480	0698-6323
A1R214	0698-6774	1	Resistor 150 \pm 0.1% .125W TF TC = 0 \pm 25	28480	0698-6774
A1R215	0698-4477	1	Resistor 10.5K \pm 1% .125W TF TC = 0 \pm 100	24546	CT4-1/8-T0-1052-F

Chapter 5 Replaceable Parts

03400-66522 Replaceable Parts (continued)

Reference Designation	HP Part Number	Qty	Part Description	Mfr. Code	Mfr. Part Number
A1R216	0698-6323		Resistor 100 ± 0.1% .125W TF TC = 0±25	28480	0698-6323
A1R217	0698-6774		Resistor 150 ± 0.1% .125W TF TC = 0±25	28480	0698-6774
A1R218	0698-4476		Resistor 10.2K ± 1% .125W TF TC = 0±100	24546	CT4-1/8-T0-1022-F
A1R219	0757-0384		Resistor 20 ± 1% .125W TF TC = 0±100	19701	5033R-1/8-T0-20R0-F
A1R220	0698-6377	1	Resistor 200 ± 0.1% .125W TF TC = 0±25	28480	0698-6377
A1R221	0757-0449	1	Resistor 20K ± 1% .125W TF TC = 0±100	24546	CT4-1/8-T0-2002-F
A1R222	0757-0401		Resistor 100 ± 1% .125W TF TC = 0±100	24546	CT4-1/8-T0-101-F
A1R301	0757-0407	2	Resistor 200 ± 1% .125W TF TC = 0±100	24546	CT4-1/8-T0-201-F
A1R302	0757-0381		Resistor 15 ± 1% .125W TF TC = 0±100	19701	5033R-1/8-T0-15R0-F
A1R303	0698-4422	1	Resistor 1.27K ± 1% .125W TF TC = 0±100	24546	CT4-1/8-T0-1271-F
A1R304	0757-0429	1	Resistor 1.82K ± 1% .125W TF TC = 0±100	24546	CT4-1/8-T0-1821-F
A1R305	0757-0407		Resistor 200 ± 1% .125W TF TC = 0±100	24546	CT4-1/8-T0-201-F
A1R306	0757-0291	1	Resistor 24.9 ± 1% .125W TF TC = 0±100	19701	5033R-1/8-T0-2492-F
A1R307-R308	0757-0277		Resistor 49.9 ± 1% .125W TF TC = 0±100	28480	0757-0277
A1R309	0757-0384		Resistor 20 ± 1% .125W TF TC = 0±100	19701	5033R-1/8-T0-20R0-F
A1R310	0757-0274	2	Resistor 1.21K ± 1% .125W TF TC = 0±100	24546	CT4-1/8-T0-1211-F
A1R311	0757-0442		Resistor 10K ± 1% .125W TF TC = 0±100	24546	CT4-1/8-T0-1002-F
A1R312	0757-0400	2	Resistor 90.9 ± 1% .125W TF TC = 0±100	24546	CT4-1/8-T0-90R9-F
A1R313	0698-3447	2	Resistor 422 ± 1% .125W TF TC = 0±100	24546	CT4-1/8-T0-422R-F
A1R314	0757-0384		Resistor 20 ± 1% .125W TF TC = 0±100	19701	5033R-1/8-T0-20R0-F
A1R315	0757-0400		Resistor 90.9 ± 1% .125W TF TC = 0±100	24546	CT4-1/8-T0-90R9-F
A1R316	2100-3094	1	Resistor-Trim 100K 10% Side-Adj 17-Turn	73138	89PR100K
A1R317	0698-8827	2	Resistor 1M ± 1% .125W TF TC = 0±100	28480	0698-8827
A1R318	0757-0472		Resistor 200K ± 1% .125W TF TC = 0±100	24546	CT4-1/8-T0-2003-F
A1R319	0757-0442		Resistor 10K ± 1% .125W TF TC = 0±100	24546	CT4-1/8-T0-1002-F
A1R320	0757-0410		Resistor 301 ± 1% .125W TF TC = 0±100	24546	CT4-1/8-T0-301R-F
A1R321	2100-3154	1	Resistor-Trim 1K 10% Side-Adj 17-Turn	73138	89PR1K
A1R322	0698-3279	1	Resistor 4.99K ± 1% .125W TF TC = 0±100	24546	CT4-1/8-T0-4991-F
A1R323	0698-8827		Resistor 1M ± 1% .125W TF TC = 0±100	28480	0698-8827
A1R324	0698-3447		Resistor 422 ± 1% .125W TF TC = 0±100	24546	CT4-1/8-T0-422R-F
A1R325	0698-4529	1	Resistor 226K ± 1% .125W TF TC = 0±100	24546	CT4-1/8-T0-2263-F
A1R326	0698-4516	1	Resistor 113K ± 1% .125W TF TC = 0±100	24546	CT4-1/8-T0-1133-F
A1R327	0757-0427	1	Resistor 1.5K ± 1% .125W TF TC = 0±100	24546	CT4-1/8-T0-1501-F
A1R328	0757-0420		Resistor 750 ± 1% .125W TF TC = 0±100	24546	CT4-1/8-T0-751-F
A1R329	0698-3700	1	Resistor 715 ± 1% .125W TF TC = 0±100	24546	CT4-1/8-T0-715R-F
A1R330	2100-3349	1	Resistor-Trim 100 10% Side-Adj 1-Turn	32997	3386X-Y46-101
A1R331	0757-0446	2	Resistor 15K ± 1% .125W TF TC = 0±100	24546	CT4-1/8-T0-1502-F
A1R332	0757-0410		Resistor 301 ± 1% .125W TF TC = 0±100	24546	CT4-1/8-T0-301R-F
A1R333	0698-3558	2	Resistor 4.02K ± 1% .125W TF TC = 0±100	24546	CT4-1/8-T0-4021-F
A1R334	0757-0280		Resistor 1K ± 1% .125W TF TC = 0±100	24546	CT4-1/8-T0-1001-F
A1R335	0757-0442		Resistor 10K ± 1% .125W TF TC = 0±100	24546	CT4-1/8-T0-1002-F
A1R336-R337	0757-0280		Resistor 1K ± 1% .125W TF TC = 0±100	24546	CT4-1/8-T0-1001-F
A1R338	0698-3558		Resistor 4.02K ± 1% .125W TF TC = 0±100	24546	CT4-1/8-T0-4021-F

03400-66522 Replaceable Parts (continued)

Reference Designation	HP Part Number	Qty	Part Description	Mfr. Code	Mfr. Part Number
A1R339	0757-0446		Resistor 15K ± 1% .125W TF TC = 0±100	24546	CT4-1/8-T0-1502-F
A1R340	0757-0410		Resistor 301 ± 1% .125W TF TC = 0±100	24546	CT4-1/8-T0-301R-F
A1R341	0757-0280		Resistor 1K ± 1% .125W TF TC = 0±100	24546	CT4-1/8-T0-1001-F
A1R342	0757-0442		Resistor 10K ± 1% .125W TF TC = 0±100	24546	CT4-1/8-T0-1002-F
A1R343	0698-4123		Resistor 499 ± 1% .125W TF TC = 0±100	24546	CT4-1/8-T0-499R-F
A1R344-R345	0757-0346		Resistor 10 ± 1% .125W TF TC = 0±100	28480	0757-0346
A1R346	0757-0274		Resistor 1.21K ± 1% .125W TF TC = 0±100	24546	CT4-1/8-T0-1211-F
A1R347	0757-0442		Resistor 10K ± 1% .125W TF TC = 0±100	24546	CT4-1/8-T0-1002-F
A1RP201	1810-0162	1	Network-Res 14-Pin 4.7 kΩ X 13	11236	760-1-R4.7K
A1SH1	03400-00607	1	Shield - RFI Left	28480	03400-00607
A1SH2	03400-00609	1	Shield - Isolation	28480	03400-00609
A1SH3	03400-00608	1	Shield - Attenuator RFI	28480	03400-00608
A1SH4	03400-00605	1	Shield - Thermocouple	28480	03400-00605
A1SH5	03400-00611	1	Shield - Resistor	28480	03400-00611
A1SH9	03400-00610	1	Shield - Input	28480	03400-00610
A1SHD5	03400-04105	1	Shield - RFI Cover	28480	03400-04105
A1TC301	0853-0003	1	Thermocouple Pair 50V +0 to +55 Deg C	28480	0853-0003
A1U101	1826-0393	2	IC V Regulator-Adj-Pos 1.2/37V 3-Pin	27014	LM317T
A1U102	1826-0527	1	IC V Regulator-Adj-Neg 1.2/37V 3-Pin	27014	LM337T
A1U103	1826-0393	1	IC V Regulator-Adj-Pos 1.2/37V 3-Pin	27014	LM317T
A1U201-U203	1820-5423	3	IC Gate CMOS/AC NAND QUAD 2-Input	27014	74AC00PC
A1U301-U302	1826-1859	2	IC OP Amp High-Slew-Rate 14-Pin	28480	1826-1859
A1U303	1826-1562	1	IC OP Amp Precision 14-Pin	28480	1826-1562
A1U304	1826-0161	1	IC OP Amp General-Purpose Quad 14-Pin	27014	LM324N

■ Replaceable Parts: 03400-66523 – Switch PC Assembly

Reference Designation	HP Part Number	Qty	Part Description	Mfr. Code	Mfr. Part Number
A2CR341-CR360	1900-0233	20	Diode-Schottky Small Signal	50088	1N5711
A2P1	03400-61607	1	Switch Cable	28480	03400-61607
A2S1	3100-3504	1	Switch-Rotary SP12T-NS .875-Center Spcg	28480	3100-3504
A2SH8	03400-01218	1	Switch Mounting Bracket	28480	03400-01218
A2TP9	8120-6113	1	Cable Assy 22-AWG 1-Cond 300 mm lg (grn)	28480	8120-6113
A2TP10	8120-6114	1	Cable Assy 22-AWG 1-Cond 300 mm lg (blk)	28480	8120-6114
A2TP11	8120-6115	1	Cable Assy 22-AWG 1-Cond 150 mm lg (blue)	28480	8120-6115
A2TP12	8120-6116	1	Cable Assy 22-AWG 1-Cond 150 mm lg (brn)	28480	8120-6116
A2TP13-TP14	03400-61608	1	LED Cable	28480	03400-61608

■ **Manufacturer's Codes: 03400-66522 and 03400-66523**

Mfr. Code	Manufacturer's Name	Manufacturer's Address	Zip Code
00779	AMP Inc	Harrisburg, PA U.S.A.	17111
01121	Allen-Bradley Co Inc	El Paso, TX U.S.A.	79935
03888	KDI Pyrofilm Corp	Whippany, NJ U.S.A.	07981
04222	AVX Corp	Great Neck, NY U.S.A.	11021
04713	Motorola Inc	Roselle, IL U.S.A.	60195
05791	Lyn-Tron Inc	Burbank, CA U.S.A.	91505
09023	Cornell-Dubilier/Sangamo	Wayne, NJ U.S.A.	07470
11238	CTS Corp	Elkhart, IN U.S.A.	46514
13103	Thermalloy Inc	Dallas, TX U.S.A.	75234
18736	Voltronics Corp	Hanover, NJ U.S.A.	07936
19701	North America Philips Corp	New York, NY U.S.A.	10017
24546	Corning Glass Works	Corning, NY U.S.A.	14830
27014	National Semiconductor Corp	Santa Clara, CA U.S.A.	95052
27264	Molex Inc	Lisle, IL U.S.A.	60532
28480	Hewlett-Packard Company - Corporate	Palo Alto, CA U.S.A.	94304
32997	Bourns Networks Inc	Riverside, CA U.S.A.	92507
46384	Penn Engineering and Manufacturing Corp	Doylestown, PA U.S.A.	18901
50088	SGS-Thomson Microelectronics Inc	Phoenix, AZ U.S.A.	85022
56289	Sprague Electric Co	Lexington, MA U.S.A.	02173
71744	General Instrument Corp	Clifton, NJ U.S.A.	07012
73138	Beckman Industrial Corp	Fullerton, CA U.S.A.	92635
74970	EF Johnson Co	Waseca, MN U.S.A.	56093
76381	3M Co	St. Paul, MN U.S.A.	55144

■ Replaceable Parts: HP 3400B Mainframe

Reference Designation	HP Part Number	Qty	Part Description	Mfr. Code	Mfr. Part Number
	03400-90014	1	English Manual (User/Service Guide)	28480	03400-90014
	1120-0308	1	Meter Mechanism - dB Scale (Opt 001 only)	28480	1120-0308
	1120-0320	1	Meter Mechanism - 3 mA Scale	28480	1120-0320
	1510-0140	1	Adapter-Dbl Binding Post to BNC	05276	1296
A1	03400-66522	1	PC Assembly - Main Board	28480	03400-66522
A2	03400-66523	1	PC Assembly - Switch Board	28480	03400-66523
BKT1	03400-01215	1	Bracket - Top Cover	28480	03400-01215
CLP1	1400-1502	1	Mounting Clip - LED Lamp	28480	1400-1502
CVR1-CVR2	03400-04107	2	Instrument Cover - Side	28480	03400-04107
CVR3	03400-04106	1	Instrument Cover - Bottom	28480	03400-04106
F1	2110-0894	1	Fuse, 250V/125 mA	28480	2110-0894
FRM3	03400-86601	1	Frame Assembly	28480	03400-86601
HDW15	2190-0016	1	Washer-Lock Intl T 3/8 In .377-In-ID	78189	1920-02
HDW22	2950-0054	1	Nut, Hex-Dbl-Cham 1/2-28-Thd .12-In-Thk	28480	2950-0054
HDW23-HDW30	2360-0192	8	Screw, 6-32 THD .25-In-Lg -HD-	28480	2360-0192
HDW31	2950-0001	1	Nut, Hex-Dbl-Cham 3/8-32-Thd .094-In-Thk	73734	9002-NP
HDW32-HDW39	2360-0322	8	Screw, 6-32 THD .375-In-Lg -HD-	28480	2360-0322
HDW40	2190-0054	1	Washer-Lock Intl T 1/2 In .505-In-ID	78189	1924-12
HDW41-HDW48	2420-0002	8	Nut, 6/32-Thd .109-In-Thk .312-A/F	28480	2420-0002
HDW50	2940-0256	1	Nut-Hex-Dbl-Cham 1/2-28-Thd .095-In-Thk	00779	1-329631-2
J2	1251-0205	1	Connector, Telephone Jack-Phone 2-Ckt	82389	2J-1432
LED1	1990-1027	1	LED Lamp	28480	1990-1027
LBL6	03400-84301	1	Label-Front Panel	28480	03400-84301
LBL7	03400-84302	1	Label-Rear Panel	28480	03400-84302
MP7	1490-0031	1	Tilt Stand 2.235-In-W 4.438-In-OA-Lg SST	28480	1490-0031
MP12	5020-6852	1	Meter Trim	28480	5020-6852
MP13-MP14	5040-7000	2	Hinge for Tilt Stand	28480	5040-7000
MP15-MP16	5060-0727	2	Foot Assembly-Bottom Cover	28480	5060-0727
MP77	0370-0077	1	Knob, Front-Panel Range	28480	0370-0077

P 3400B Mainframe Replaceable Parts (continued)

Reference Designation	HP Part Number	Qty	Part Description	Mfr. Code	Mfr. Part Number
PB1	5041-0564	1	Pushbutton - Power-On Push Rod	28480	5041-0564
PNL1	03400-00205	1	Instrument Panel - Front	28480	03400-00205
PNL2	03400-00217	1	Instrument Panel - Rear	28480	03400-00217
PWR1	9135-0484	1	Power Module	06328	CD24.4198.151
PWR2	9135-0485	1	Fuse Drawer/Fuse	06328	4303.2036.01
RD1	03458-43702	1	Power-On Push Rod	28480	03458-43702
RD2	5040-7675	1	Switch - Power-On Push Rod	28480	5040-7675
SCR1	2360-0113	1	Screw, 6-32 Thd .25-In-Lg -HD-	28480	2360-0113
SCR23	2360-0194	1	Screw, 6-32 Thd .312-In-Lg -HD-	28480	2360-0194
SH10	03400-64104	1	Instrument Cover - Top	28480	03400-64104
T1	9100-5029	1	Power Transformer	17474	14-7345
TBG1	0890-0103	1	Tubing-HS .25-IN-D/.125-In-Rcvd	06090	VERSAFIT-1/4-WHT
TBG2	0890-1616	1	Tubing-HS .145-IN-D/.1-In-Rcvd	76381	3020-030
W4	8120-1378	1	Power Cord - U.S.	16428	CH7081
W5	8120-3872	1	Jumper Assy 22-AWG 1-Cond 300 mm (red)	28480	8120-3872
WSH5	3050-0604	1	Washer-Flat 7/16 In .5-In-ID .75-In-OD	86928	5710-94-16
WSH23	3050-0067	1	Washer-Flat Mtlc 5/16 In .375-In-ID	73734	31-550

■ Manufacturer's Codes: HP 3400B Mainframe

Mfr. Code	Manufacturer's Name	Manufacturer's Address	Zip Code
00779	AMP Inc	Harrisburg, PA U.S.A.	17111
05275	ITT Pomona Electronics	Pomona, CA U.S.A.	91766
06090	Raychem Corp	Menlo Park, CA U.S.A.	94025
16428	Cooper Industries Inc	Houston, TX U.S.A.	77210
17474	Tranex Inc	Sunnyvale, CA U.S.A.	94068
28480	Hewlett-Packard Company - Corporate	Palo Alto, CA U.S.A.	94304
73734	Federal Screw Products Co	Chicago, IL U.S.A.	60618
78189	Illinois Tool Works Inc Shakeproof	Elgin, IL U.S.A.	60126
76381	3M Company	St. Paul, MN U.S.A.	55144
82389	Switchcraft Inc	Chicago, IL U.S.A.	60630
86928	Seastrom Manufacturing Co	Glendale, CA U.S.A.	91201
06328	Schurter Inc	Petaluma, CA U.S.A.	94954

 Backdating

Backdating

This chapter normally contains information necessary to adapt this manual to instruments not directly covered by the current content. At this printing, however, the manual does apply to all instruments. Therefore, no information is included in this chapter.

Schematics

Schematics

- Mechanical Disassembly 67
- Component Locator Diagrams 68
- Input Attenuator, Impedance Converter, and Power Supplies 69
- Relay Drivers and Post Attenuator 70
- Wideband Amplifier, Chopper Op Amp, and Overload Detector 71
- Switch Board Schematic 72

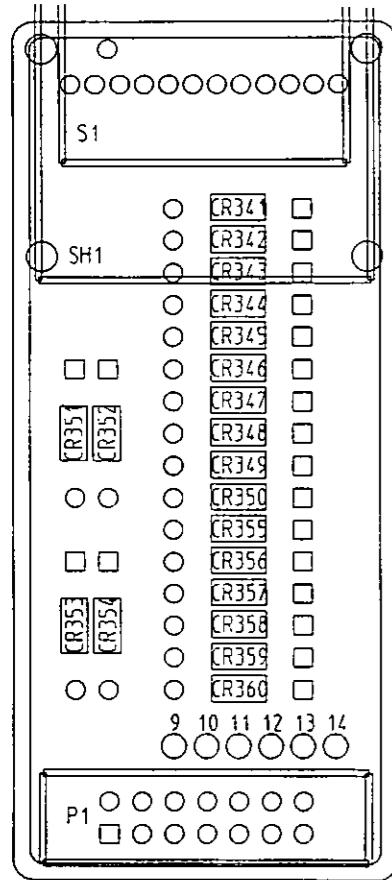

03400-66523
SWITCH PC ASSEMBLY

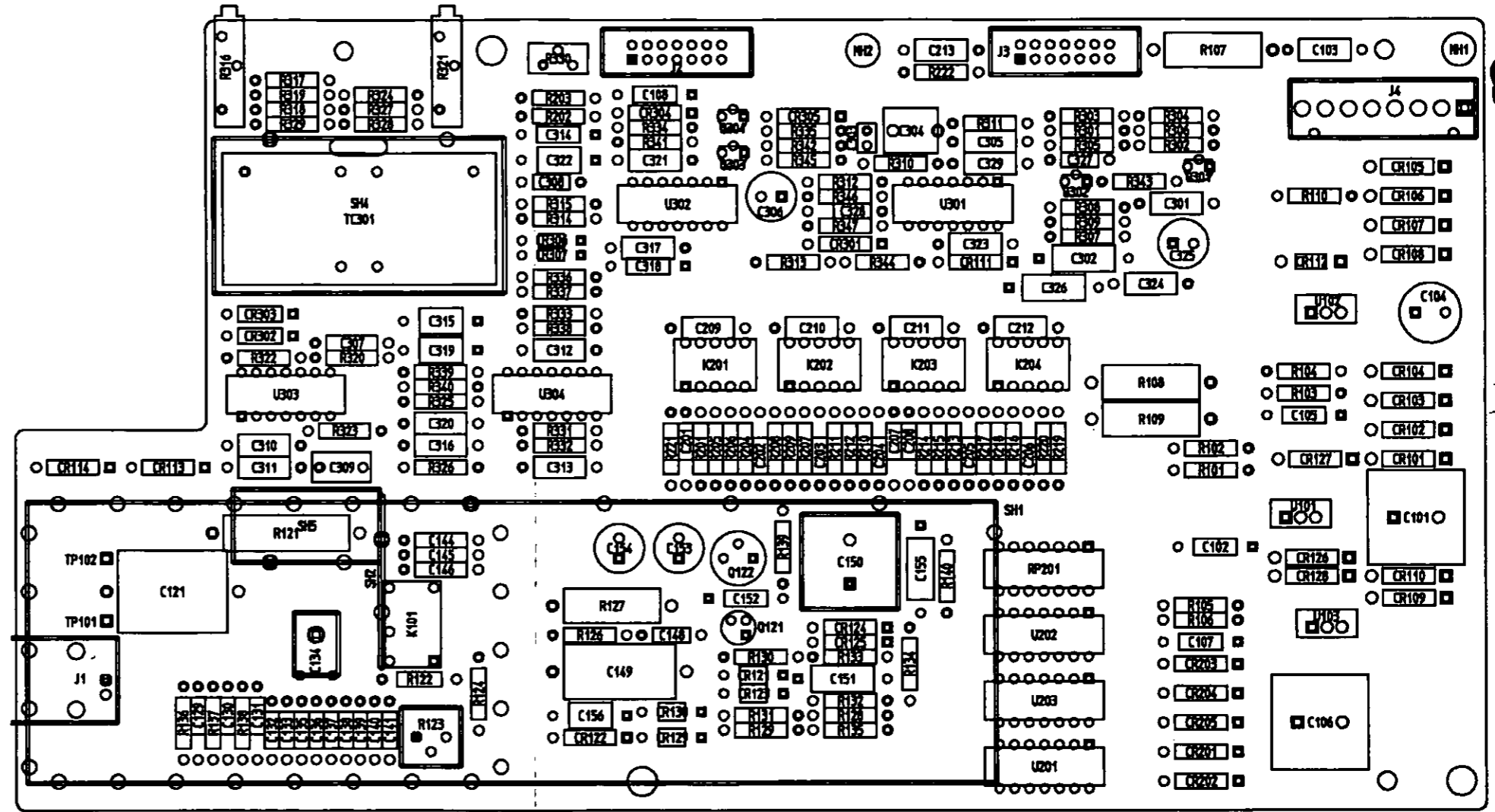

03400-66522
MAIN PC ASSEMBLY

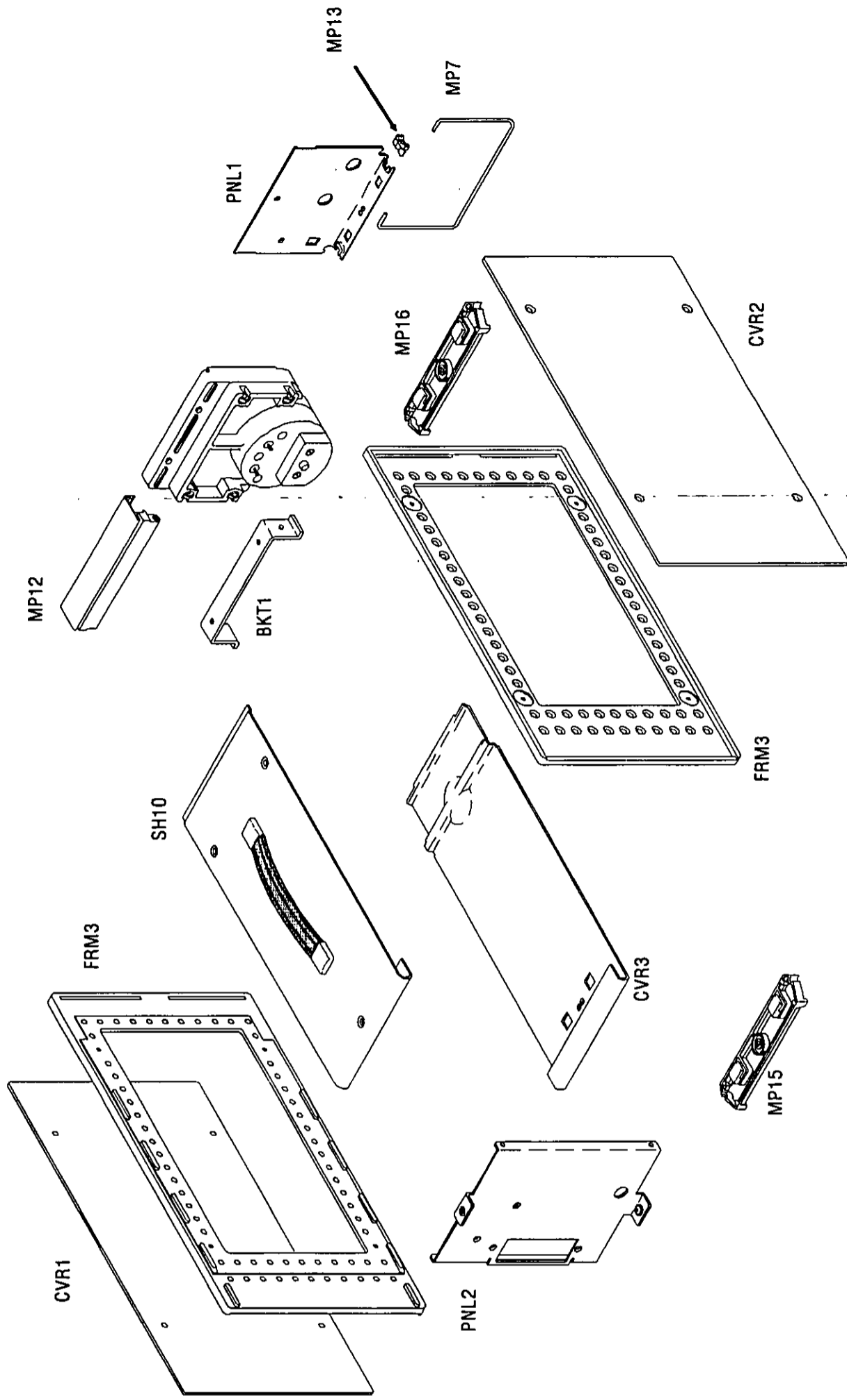

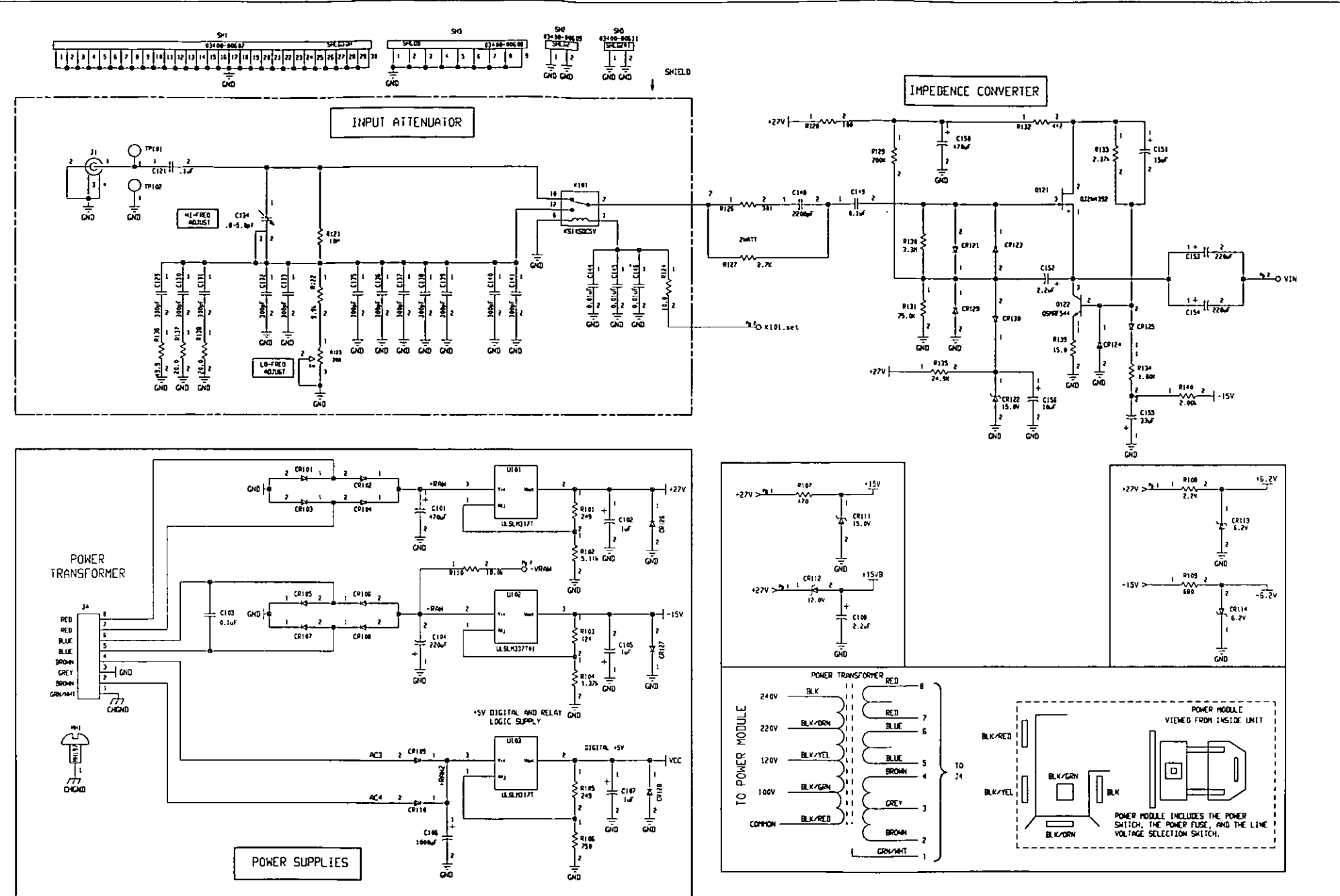

October 1992 03400-66522 INPUT ATTENUATOR, IMPEDANCE CONVERTER, and POWER SUPPLIES 1

Input Attenuator, Impedance Converter, and Power Supplies 69

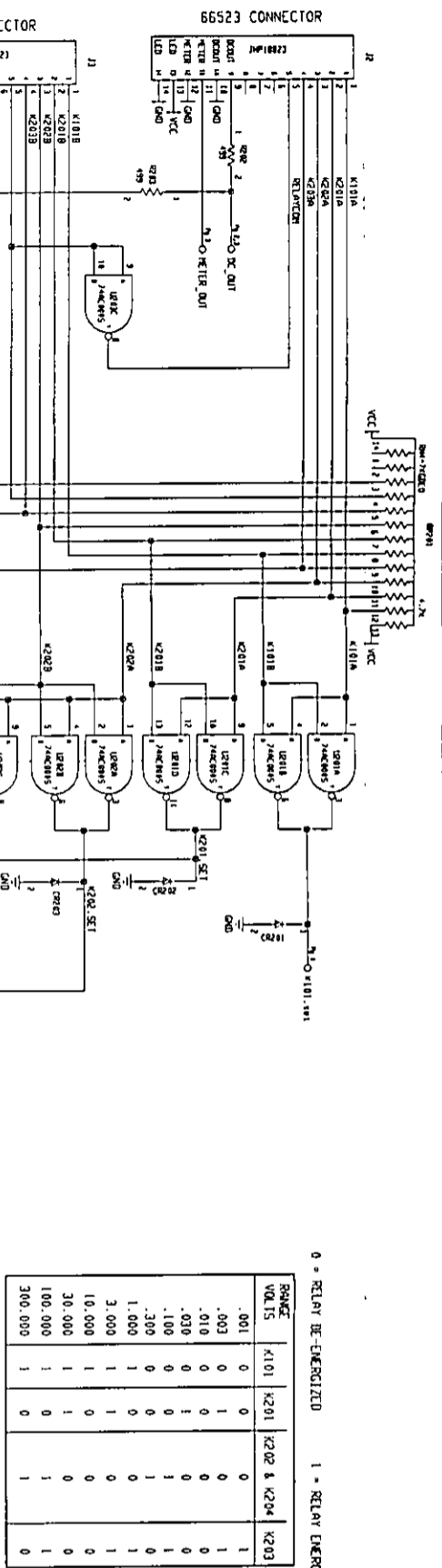

0 = RELAY DE-ENERGIZED 1 = RELAY ENERGIZED

RANGE VOLTS	K101	K201	K202 & K204	K203
.001	0	0	0	1
.003	0	1	0	0
.010	0	0	0	0
.030	0	1	0	1
.100	0	0	1	0
.300	0	0	1	0
1.000	1	0	0	1
3.000	1	1	0	1
10.000	1	0	0	0
30.000	1	1	0	0
100.000	1	0	1	1
300.000	1	0	1	0

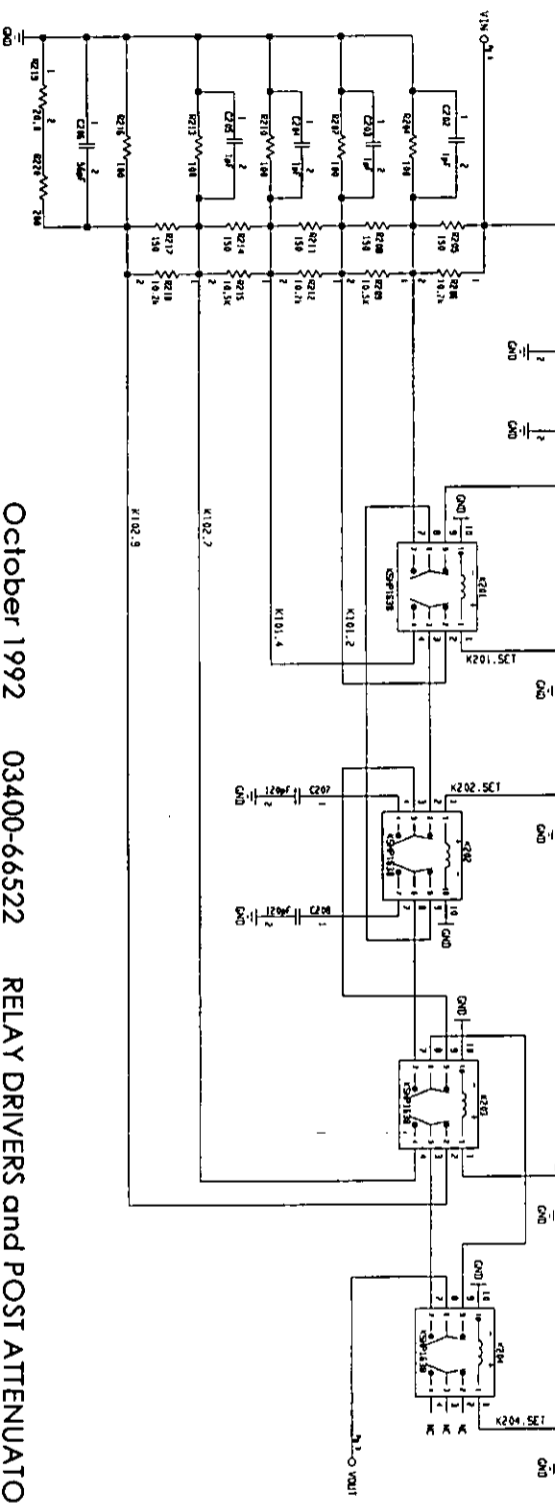
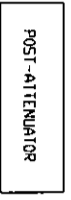
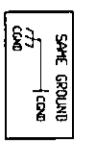

October 1992 03400-66522 RELAY DRIVERS and POST ATTENUATOR

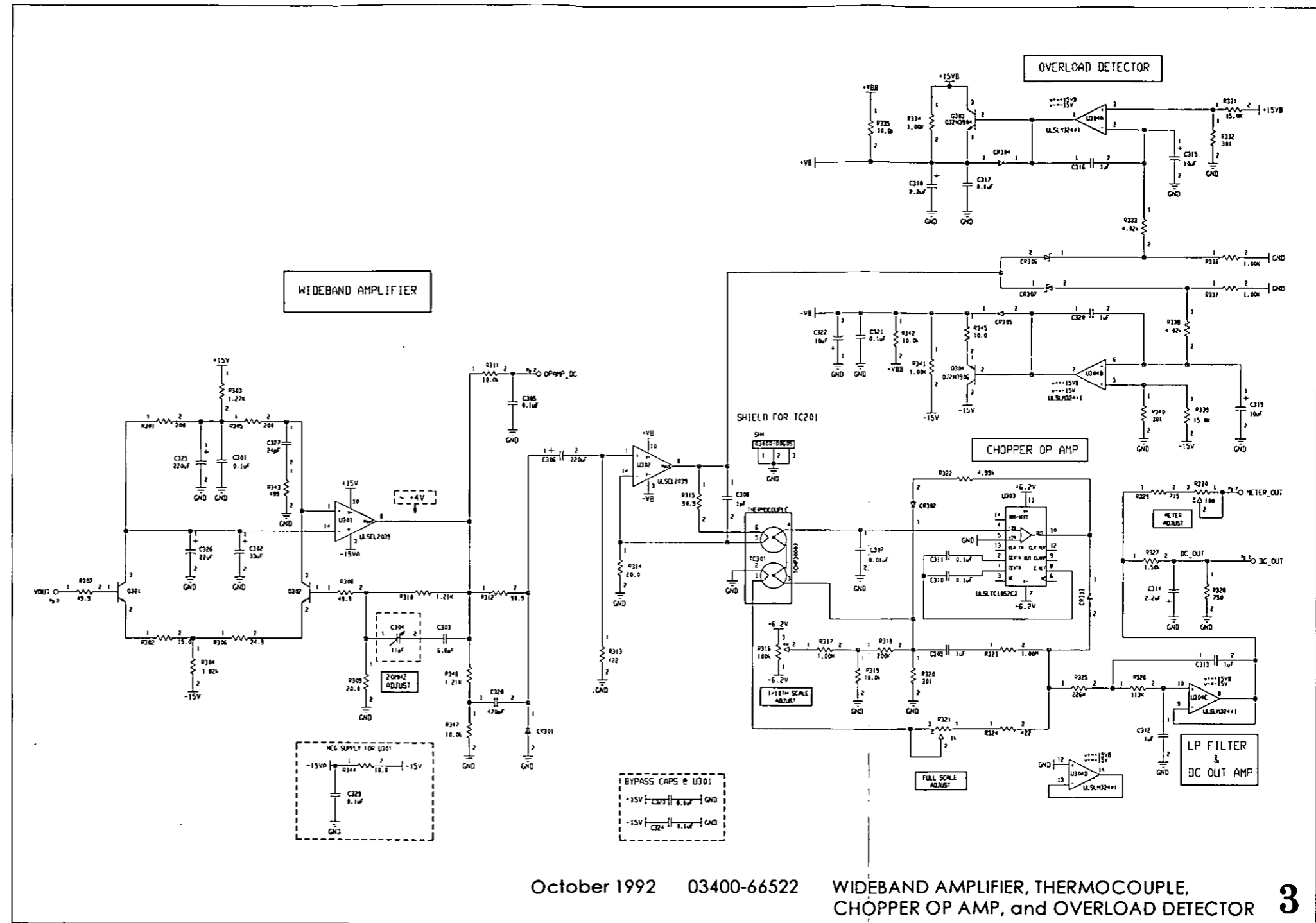

October 1992 03400-66522 WIDEBAND AMPLIFIER, THERMOCOUPLE, CHOPPER OP AMP, and OVERLOAD DETECTOR **3**

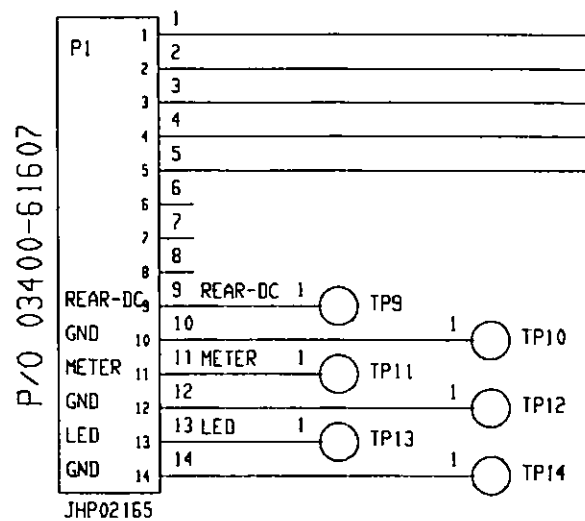

- TP9 = 300mm GREEN
- TP10 = 300mm BLK
- TP11 = 150mm BLUE
- TP12 = 150mm BROWN
- TP13 = LED CABLE RED
- TP14 = LED CABLE BLACK

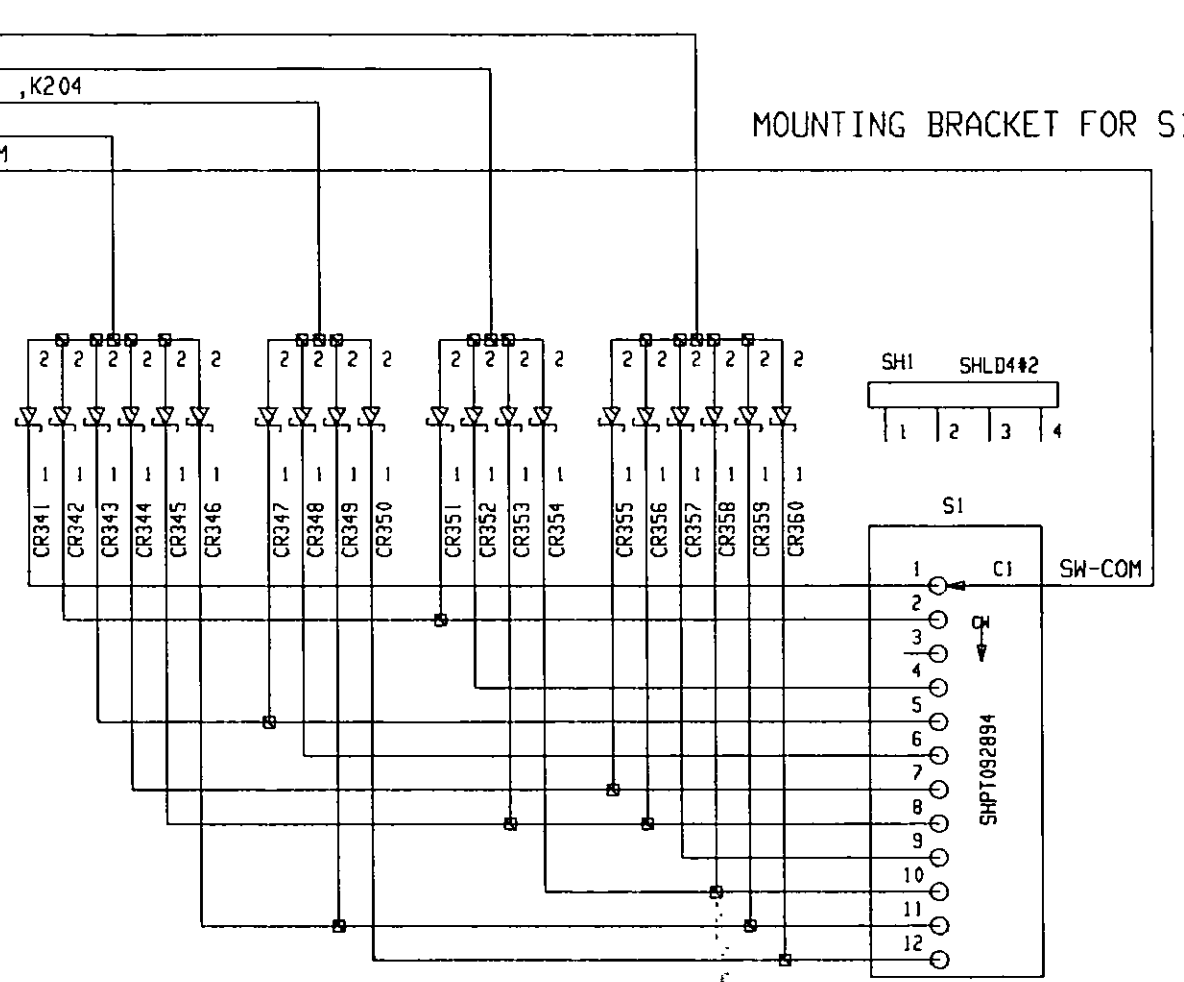

Index

- A**
ac-to-dc converter accuracy, 4
accessory
 checklist, 11
 phone plug, 14
 rack mounting, 16
accuracy
 ac-to-dc converter specifications, 4
 measurement specifications, 4
adapter, double binding post, 11
adapter frame, rack mounting, 16
 adjustment procedures, 28
 adjustment screw, 2, 13, 28
amplifier stability test, 25
- B**
backdating, 63
binding post adapter, 11
block diagram, 39
BNC adapter, 11
BNC input terminal, 2
- C**
calibration
 interval, 19
 procedures, 17
 temperature, 20
 test equipment required, 20
 time required, 19
 cautions and warnings, 5
checklist
 items included, 11
 operating, 49
chopper op amp description, 43
coefficient, temperature, 4
combining case, rack mounting, 16
component locators, 68
contents, table of, 7
cord, power, 11
crest factor, 4
crest factor check, 27
- D**
dc output, full-scale output, 14
dc output jack, 3, 14
Declaration of Conformity, *back cover*
dimensions, product, 4
double binding post adapter, 11
- E**
electrostatic discharge precautions, 50
equipment required, calibration, 20
- F**
factory setting, line voltage, 11
feature overview, 1
feet, removing, 15
flatness adjustment, 33
Fluke 5700A Calibrator, 20
front panel
 labels, 2
 pictorial overview, 2
full-scale gain adjustment, 29
full-scale output, dc output jack, 14
full-scale test, frequency response, 23
fuse
 factory configuration, 11
 fuse-holder location, 2, 12
 part number, 49
 replacing, 49
fuse-holder assembly, 3, 12, 49
- H**
HP 3458A Multimeter, 20
HP 8161A Pulse Generator, 20
- I**
impedance converter description, 41
input attenuator
 adjustment, 34
 description, 41
input impedance, 4
input terminal, 2
interval, calibration, 19
- J**
J3 pinout (test connector), 36jack,
rear-panel, 3, 14
- K**
kits, rack mounting, 16
- L**
labels
 front panel, 2
 rear panel, 3
line fuse
 factory configuration, 11
 fuse-holder location, 2, 12
 part number, 49
 replacing, 49
line voltage
 changing, 12
 factory setting, 11
 module location, 3, 12
 voltage setting, 3, 12
- M**
manual overview, 6
measurement accuracy, 4
measurement range, selecting, 13
mechanical disassembly, 67
meter zero adjustment, 28
mounting, rack, 15
- N**
needle adjustment, 28, 32
needle adjustment, full scale, 32

O

offset, zero, 4, 13
operation verification procedures, 21
operating checklist, 49
output jack, rear-panel, 3, 14
overload protection check, 26
overview
 front panel, 2
 manual, 6
 rear panel, 3

P

parts lists, 51
performance verification, 22
phone plug, output jack, 14
pinout, test connector, 36
plug, output jack, 14
pointer adjustment, 28, 32
post attenuator description, 42
power cord, 11
power supply description, 44
power-line fuse
 factory configuration, 11
 fuse-holder location, 2, 12
 part number, 49
 replacing, 49
power-line voltage
 changing, 12
 factory setting, 11
 module location, 3, 12
 voltage setting, 3, 12
procedures
 adjustment, 28
 operation verification, 21
 performance verification, 22
product
 description, 1
 dimensions, 4
 specifications, 4
 weight, 4
protection circuitry test, 26

R

rack adapter frame, 16
rack mounting
 adapter frame, 16
 combining case, 16
range, frequency response test, 22
range selection, 13
range switch, 2, 13
rear panel overview, 3
rear-panel
 labels, 3
 output jack, 3, 14
 pictorial overview, 3
relay drivers, 45
replaceable parts
 lists, 51
 ordering, 52
response time, 4
ribbon cable, custom, 36

S

schematic diagrams, 14, 65
screw, zero adjustment, 2, 13, 28
source impedance, output jack, 4, 14
specifications, 4
static electricity, 18, 50
switch board description, 45

T

table of contents, 7
temperature coefficient, 4
tenth scale gain adjustment, 30
tenth scale test, 24
terminal, input, 2
test connector pinout, 36
test considerations, 20
test equipment, calibration, 20
theory of operation, 37
thermocouple pair description, 43
time required, calibration, 19

V

voltage range selection, 13
voltage range switch, 2, 13
voltage, power-line
 changing, 12
 factory setting, 11
 module location, 3, 12
 voltage setting, 3, 12

W

warm-up time, 11, 20, 22, 28
warnings and cautions, 5
warranty information, *front cover*
weight, product, 4
wideband amplifier description, 42

Z

zero adjustment, 28, 32
zero adjustment screw, 2, 13, 28
zero offset, 4, 13

Declaration of Conformity
According to ISO/IEC Guide 22 and EN 45014

The Hewlett-Packard Company declares that the *HP 3400B Voltmeter* conforms to the following Product Specifications.

Safety: IEC 1010-1 (1990)
CSA 231
UL 1244

EMC: CISPR 11:1990/EN55011 (1991): Group 1 Class A
IEC 801-2:1991/EN50082-1 (1992): 4 kV CD, 8 kV AD
IEC 801-3:1984/EN50082-1 (1992): 3 V/m
IEC 801-4:1988/EN50082-1 (1992): 1 kV

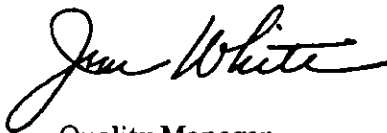

Quality Manager
October 1992

In the United States:
Hewlett-Packard Company
P.O. Box 301
815 14th Street S.W.
Loveland, Colorado 80539 U.S.A.

In Europe:
Hewlett-Packard GmbH
Department ZQ / Standards Europe
Herrenberger Straße 130
D-7030 Böblingen
(FAX: +49-7031-141623)

Contents

The Front Panel at a Glance	2
The Rear Panel at a Glance	3
Specifications	4
In This Book	5
Chapter 1 – Quick Start	9
Chapter 2 – Calibration Procedures	17
Chapter 3 – Theory of Operation	37
Chapter 4 – Service	47
Chapter 5 – Replaceable Parts	51
Chapter 6 – Backdating	63
Chapter 7 – Schematics	65
Index	73



Hewlett-Packard Company
Printed in U.S.A.
Edition 1
October 1992 E1092



03400-90014